

1.

2.

3.

4.

5.

6.

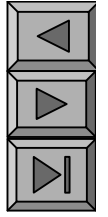

1.

()

()

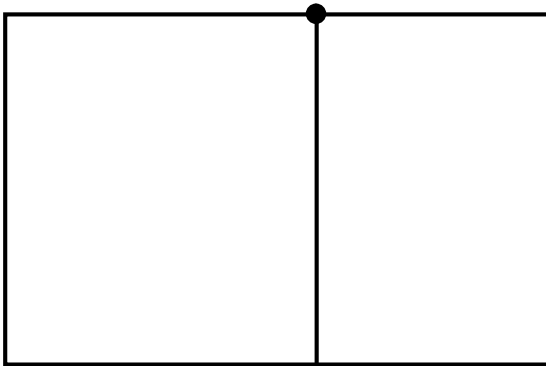



2010 3 3



3





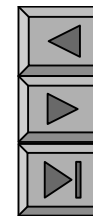

2.

(1)

□

(2)

(3)

(4)

(5)

“ ”

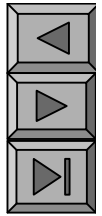

3.

$I \quad U$

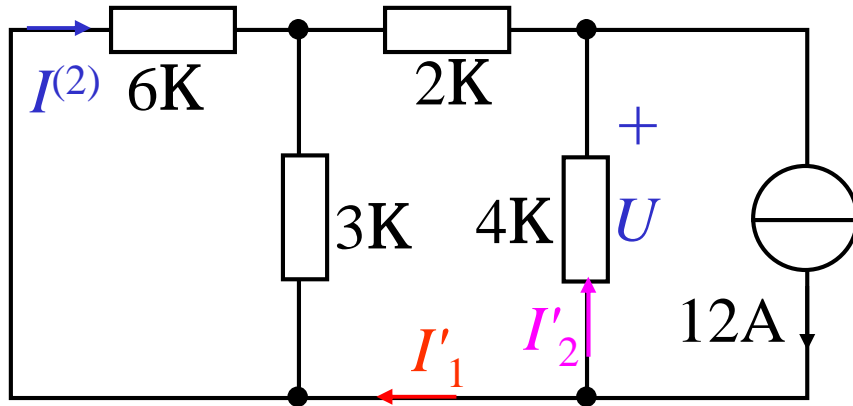

$$I'_1 = 1 \frac{4 \cdot 12}{4 + \left(2 + \frac{6 \cdot 3}{6+3} \right)}$$

1.6 A

$$I^{(1)} = \frac{120}{6 + \frac{3 \cdot (2+4)}{3 + (2+4)}} = 15 \text{ A}$$

$$I^{(2)} = 1 \frac{3}{6+3} \cdot 6 \cdot 12 \text{ A}$$

$$U^{(2)} = 1 \cdot 6 \cdot 4 \cdot 12 \text{ V}$$

$$U^{(1)} = \frac{3 \cdot I^{(1)}}{3 + (2+4)} \cdot 4 = 20 \text{ V}$$

$$I = 17 \text{ A} \quad U = 4 \text{ A}$$

P85 4-2

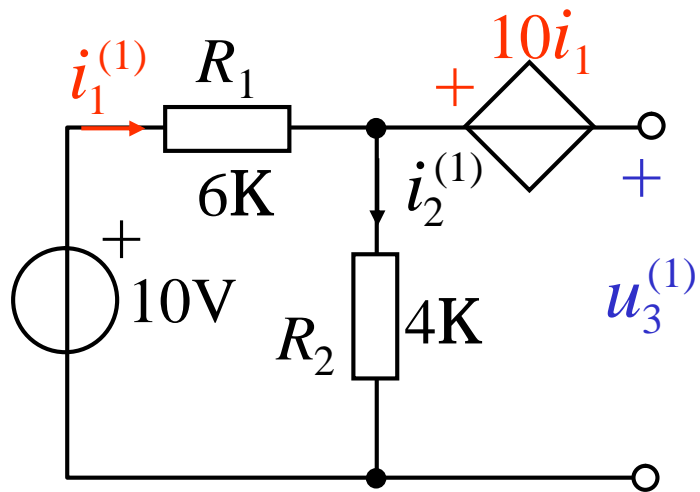

$$i_1^{(1)} = 1 \quad i_2^{(1)} = 1 \quad \frac{10}{6+4} = 1.1 \text{ A}$$

$$u_3^{(1)} = 10 i_1^{(1)} + 4 i_2^{(1)} = 11 \text{ V}$$

$$i_1^{(2)} = 1 \quad \frac{4}{6+4} = 0.4 \quad 1 = 1.6 \text{ A}$$

$$u_3^{(2)} = 10 i_1^{(2)} + 4 i_2^{(2)} = 25.6 \text{ V}$$

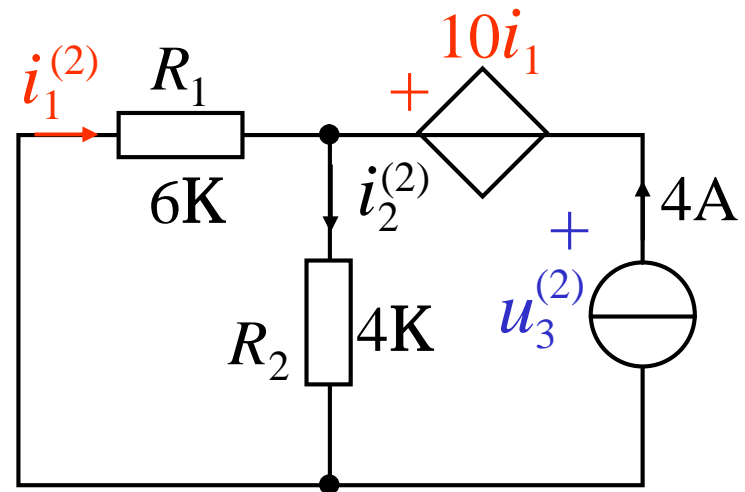
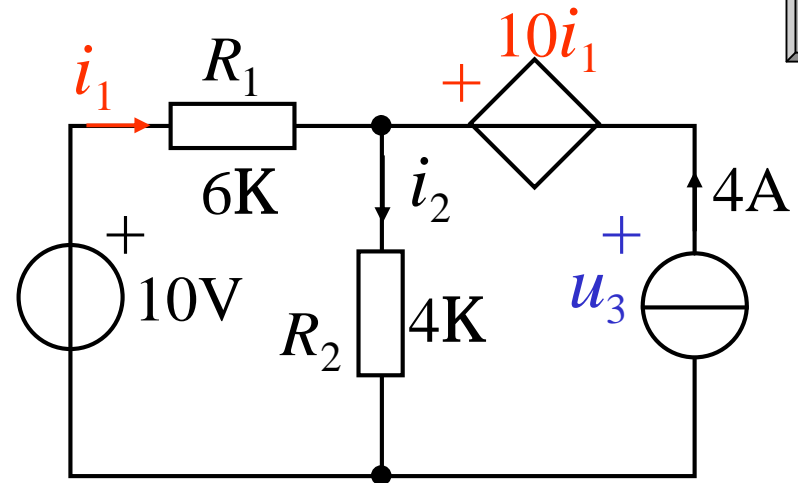
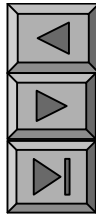

$$u_3 = 11 + 25.6 = 36.6 \text{ V}$$

P86 4-3

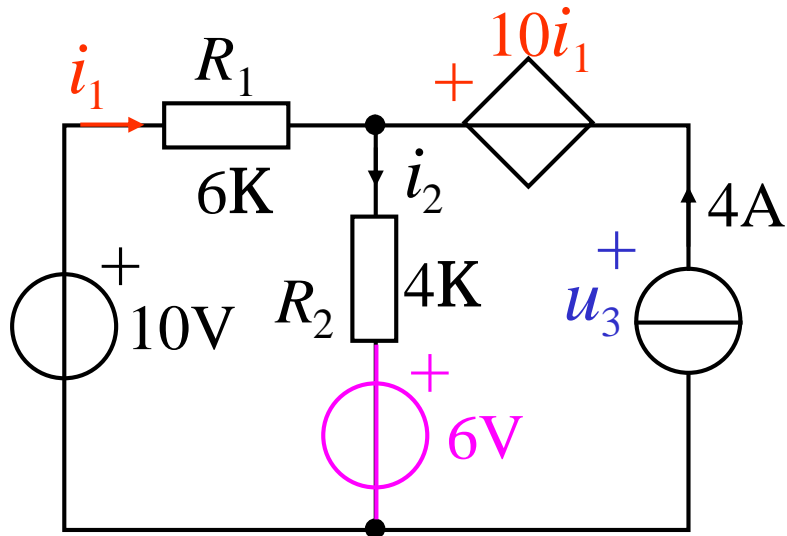

10V

4A

$$u_3^{(1)} = 19.6V$$

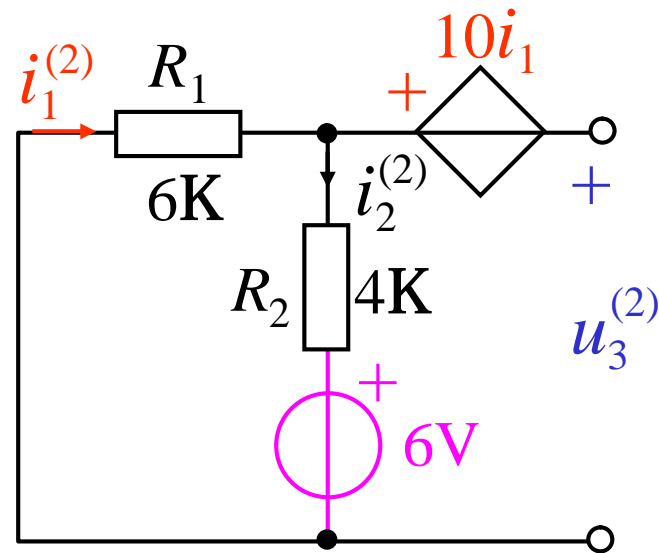

$$i_1^{(2)} = i_2^{(2)} = \frac{6}{6+4} = 0.6A$$

$$u_3^{(2)} = 10 i_1^{(2)} - 6 i_1^{(2)}$$

$$= 16 (0.6) = 9.6V$$

$$u_3 = u_3^{(1)} + u_3^{(2)} = 29.2V$$

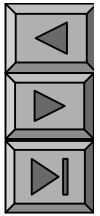

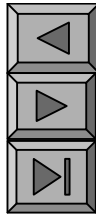

$$K u_f = \left[\sum_{m=1}^g k_{fm} u_s + \sum_{m=1}^h K_{fm} i_s \right] K$$

4. $f(Kx) = K f(x)$

• $(K \quad) \quad (\quad) \quad K$
 K

-
- K
-
-

P87 4-4

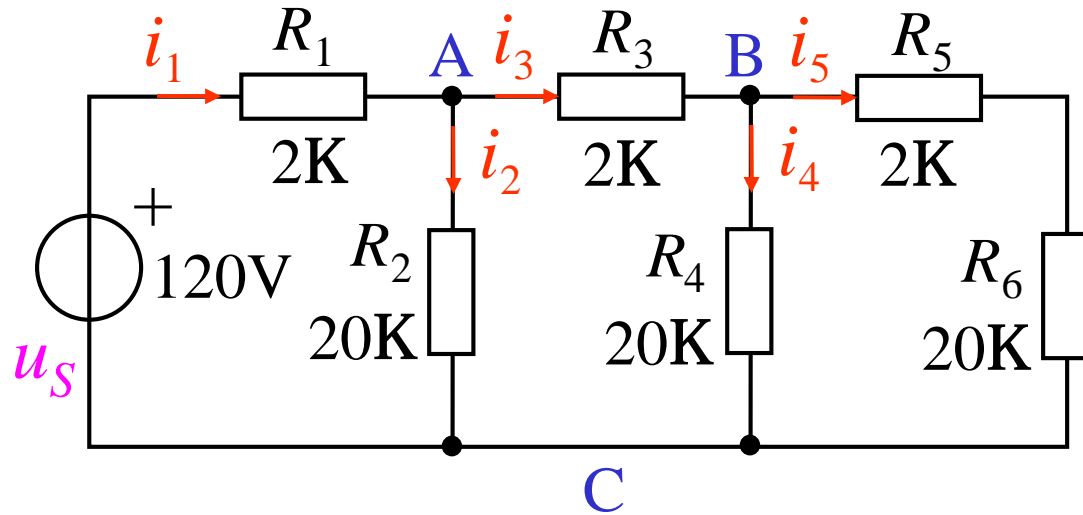

$$i_5 = i'5 = 11\text{A}$$

$$u'_{BC} = (2\check{Z} + 20) i'5 = 22\text{V}$$

$$i'_4 = \frac{u'_{BC}}{R_4} = \frac{22}{20} = 11.1\text{A}$$

$$i'_3 = i'_4 \check{Z} i'5 = 2.1\text{A}$$

$$u'_{AC} = R_3 i'_3 \check{Z} u'_{BC}$$

12

P87 4-4

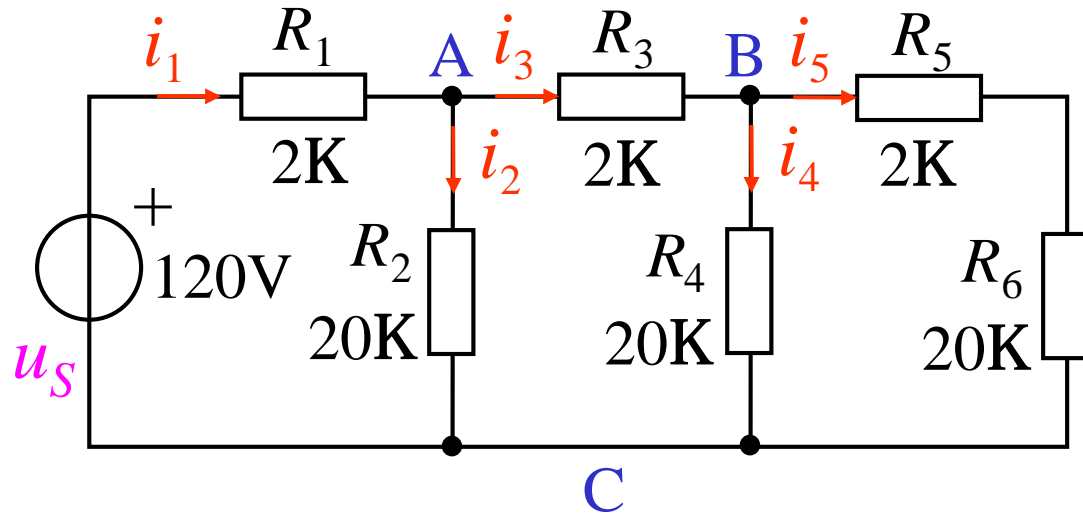

$$i_5 = i'_5 = 1\text{A}$$

$$u'_S = 33.02\text{V}$$

$$u'_S = K1 \frac{120}{33.02}$$

$$K = 3.634$$

$$i_1 = K i'_1 = 12.39\text{A}$$

$$i_2 = K i'_2 = 4.76\text{A}$$

$$i_3 = K i'_3 = 7.63\text{A}$$

$$i_4 = K i'_4 = 4.00\text{A}$$

$$i_5 = K i'_5 = 3.63\text{A}$$

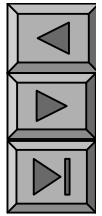

4 2

• u_k i_k k

(1) u_k

(2) i_k

(3) $\frac{u_k}{i_k}$

•

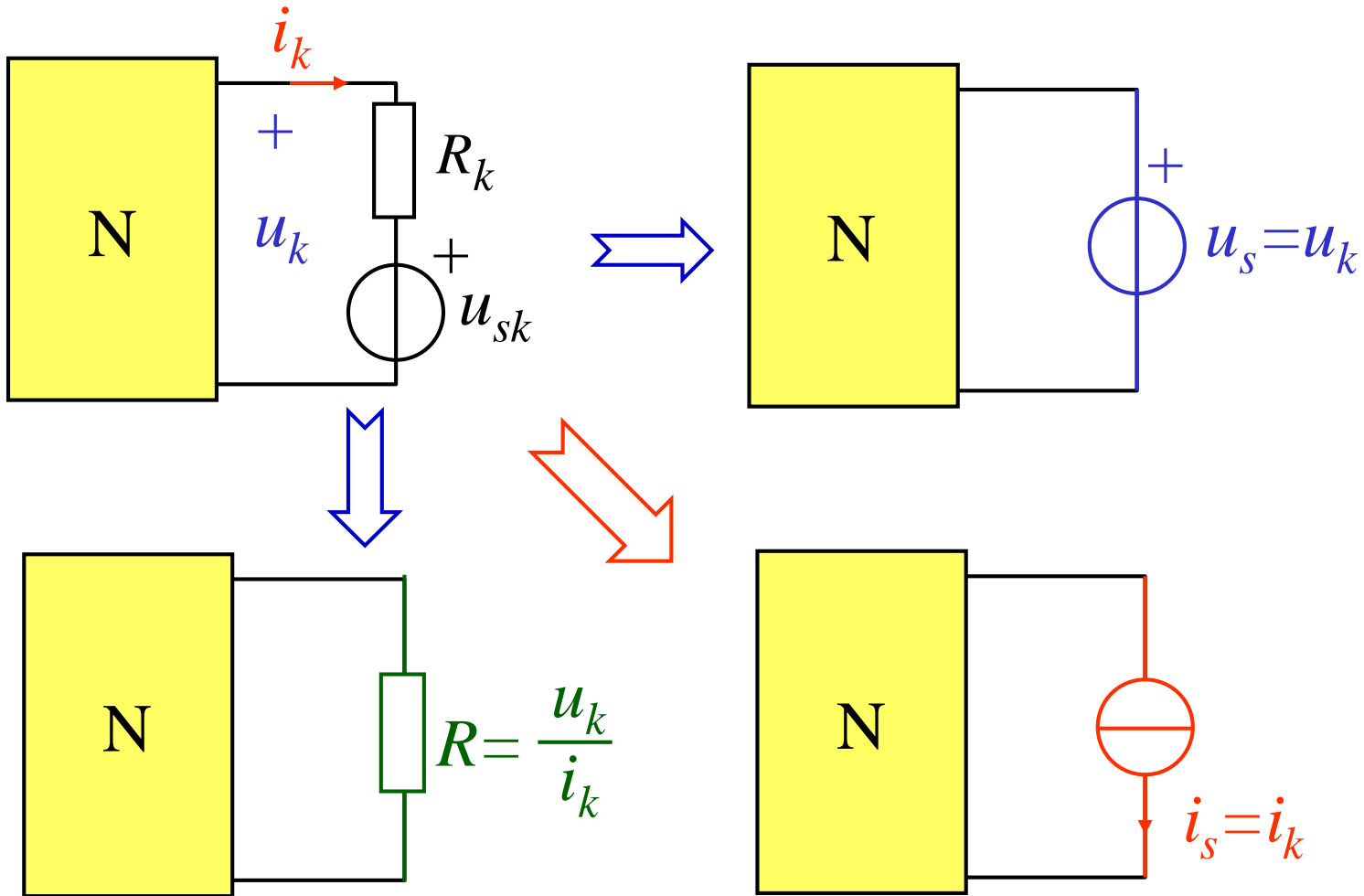
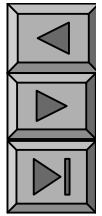

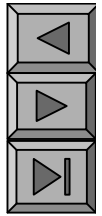

- ()

- KCL KVL

- $(\begin{matrix} u_k(& i_k) \\ &) \end{matrix} \quad u_k(\quad i_k)$

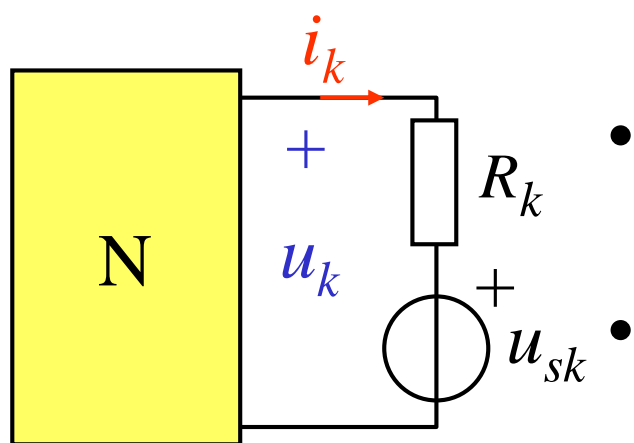
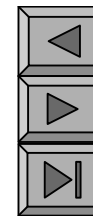

u_k

KCL

KVL

“N”

“N”

k

u_k

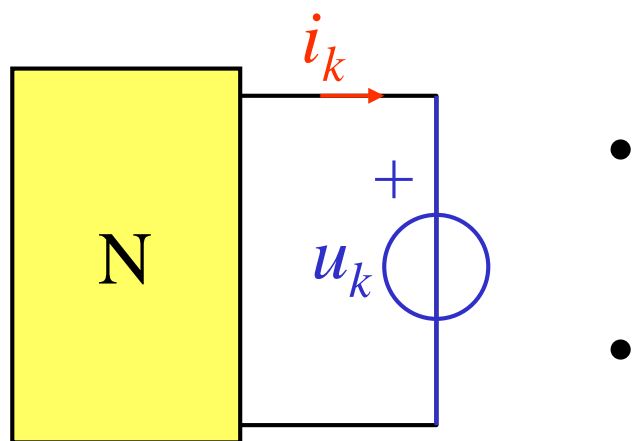

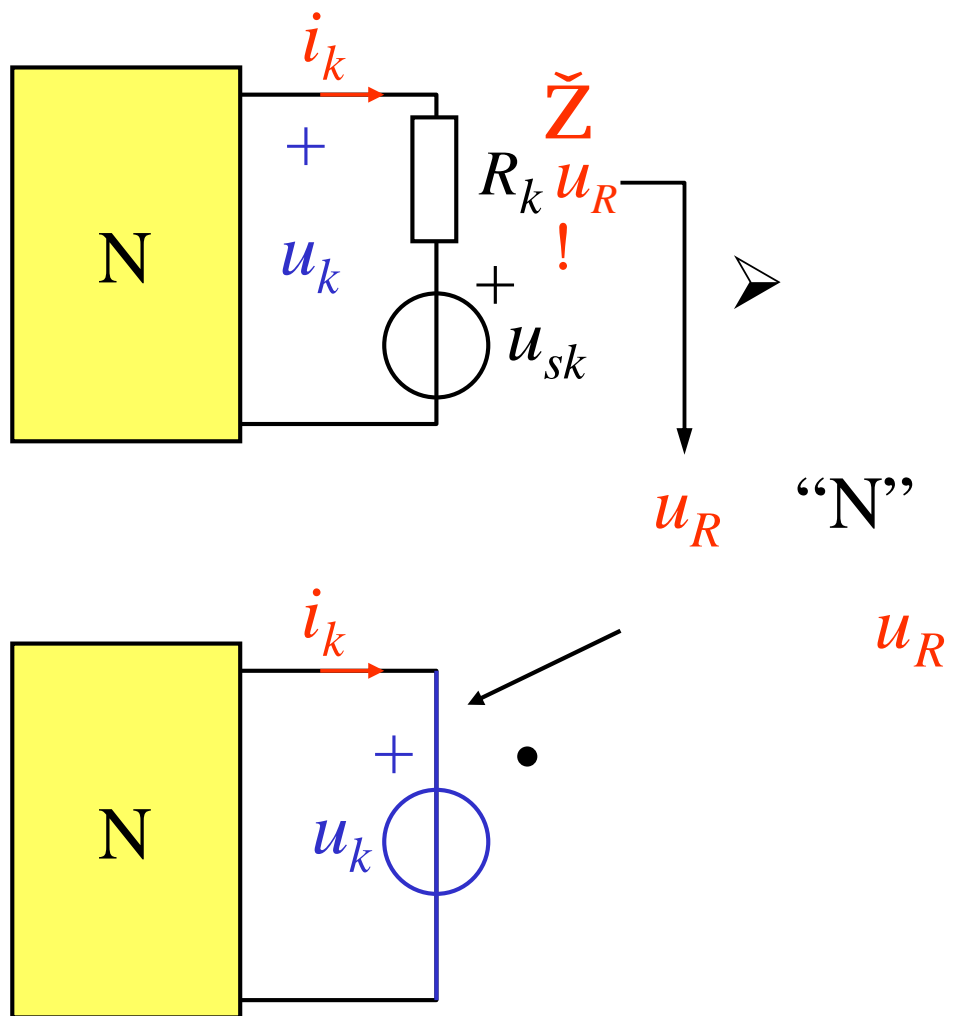
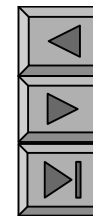

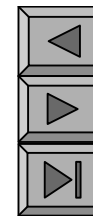

1

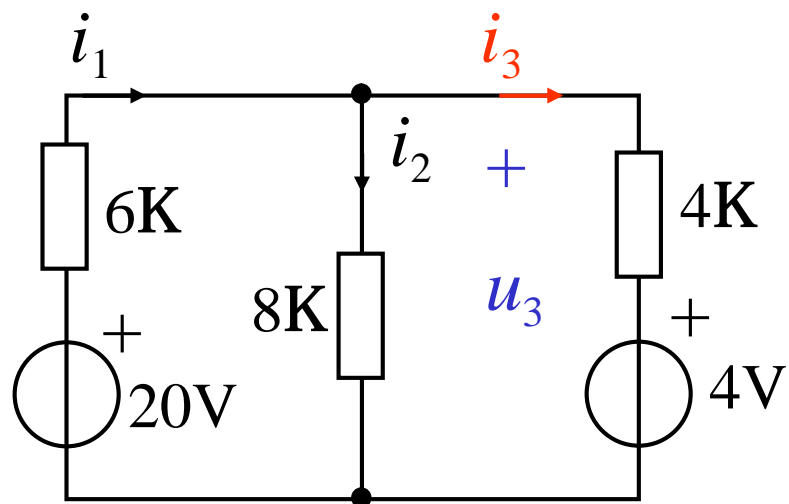

$$u_3 = 1.8V$$

$$i_1 \quad i_2 \quad i_3$$

$$i_2 = 1 \frac{8}{8} = 1.1A$$

$$i_1 = 1 \frac{20 - 8}{6} = 1.2A$$

$$i_3 = 1 i_1 - i_2 = 1.1A$$

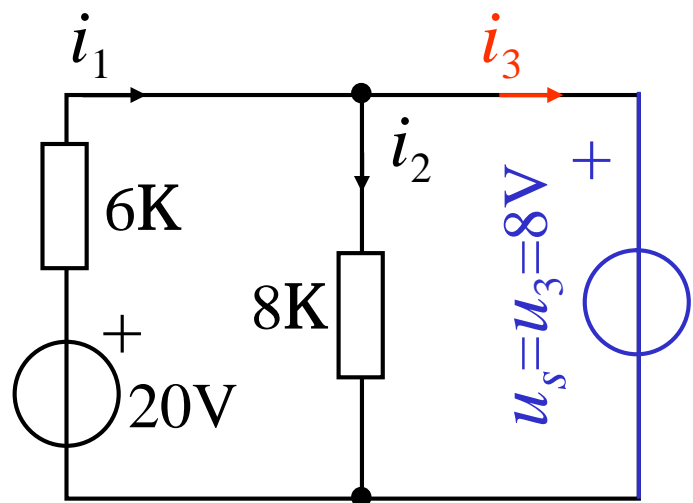

$$8V$$

$$u_3$$

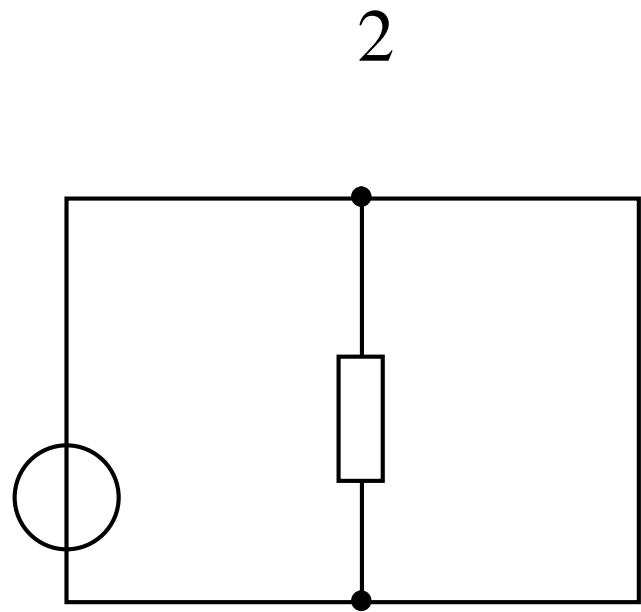

$$i_3 = 1A$$

i_2 u_3

i_1

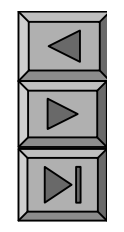

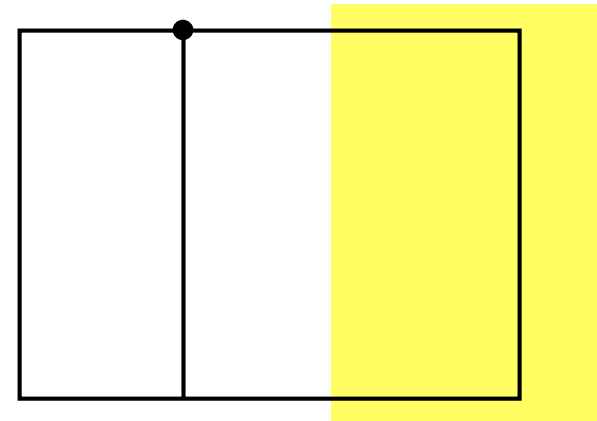
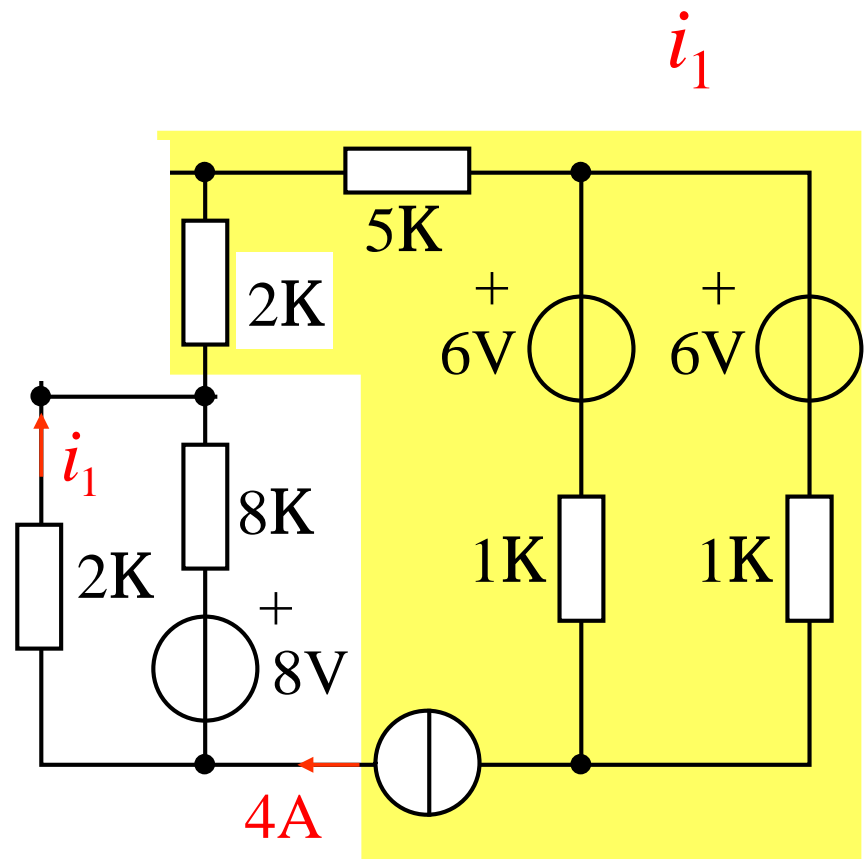
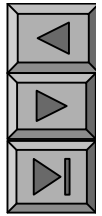

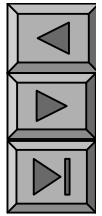

•

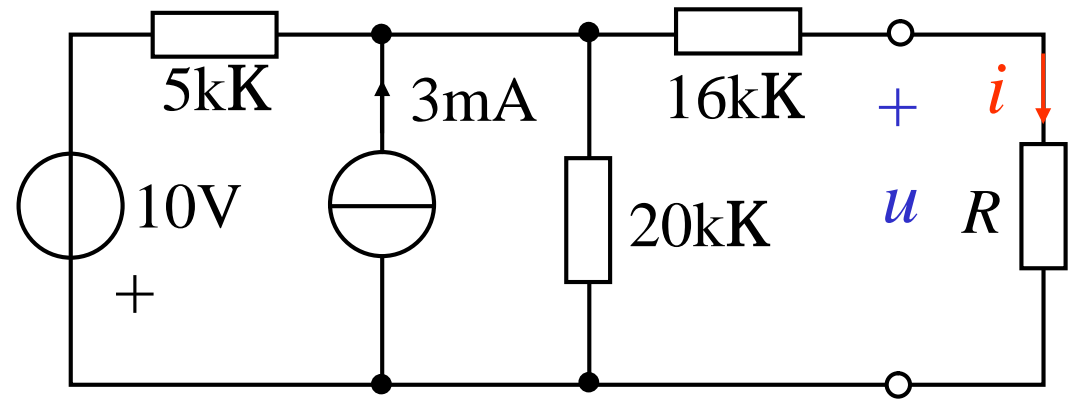

$i=?$

$u=?$

$R=?$

?

•

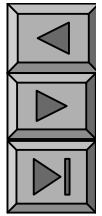

1.

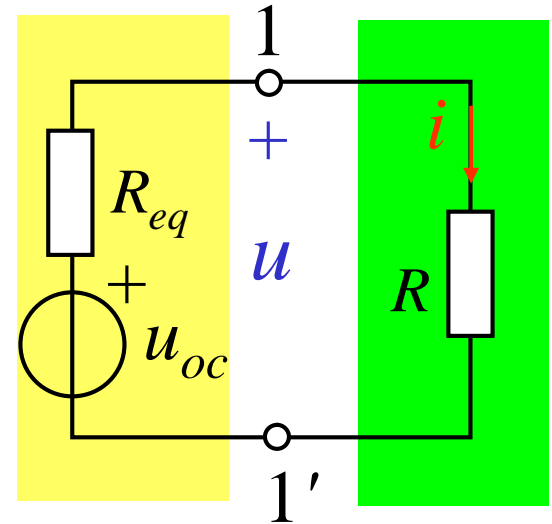
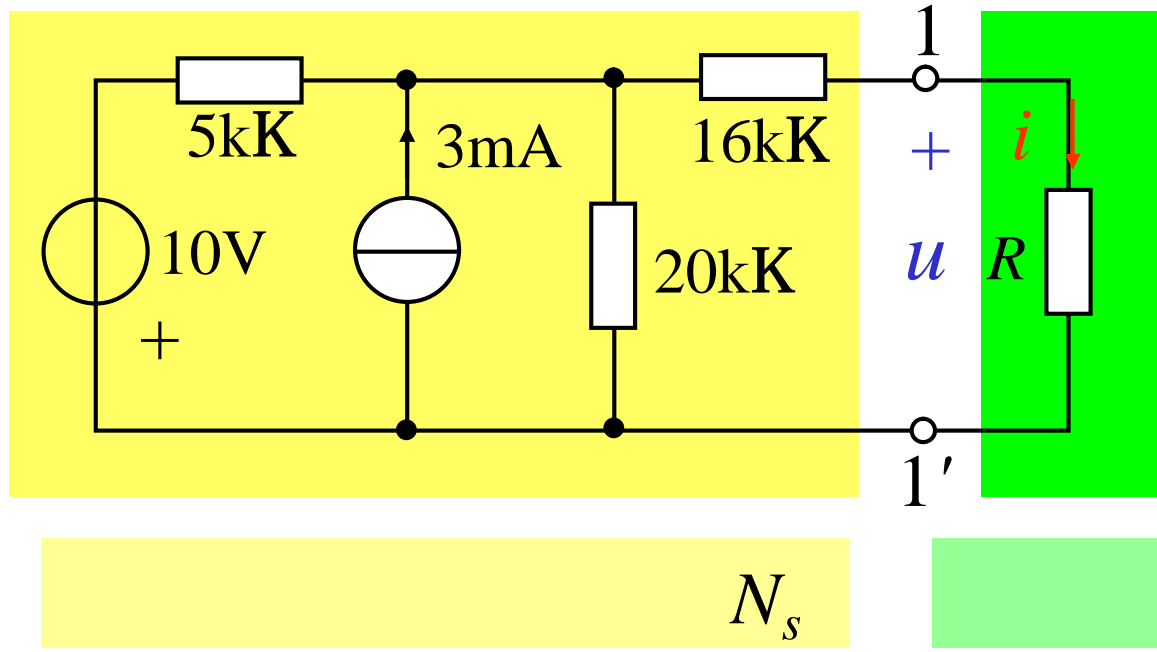
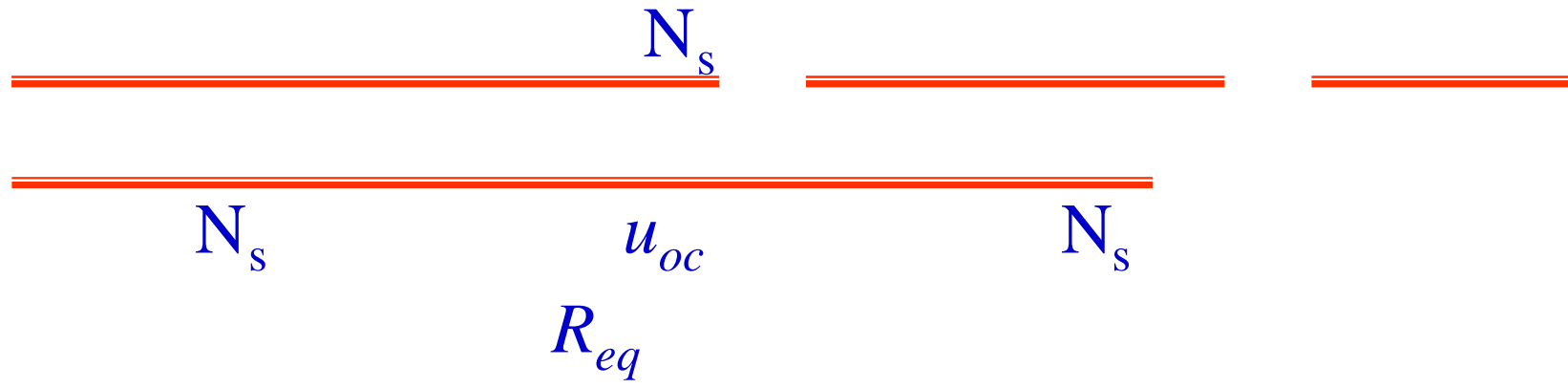

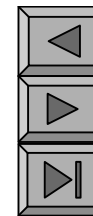

N_s

N_s

u_{oc}

N_s

R_{eq}

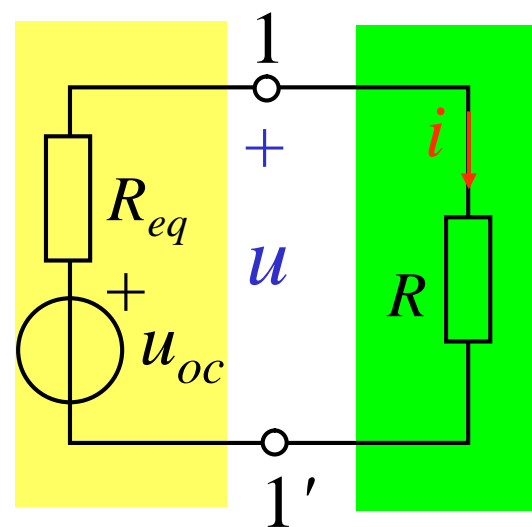
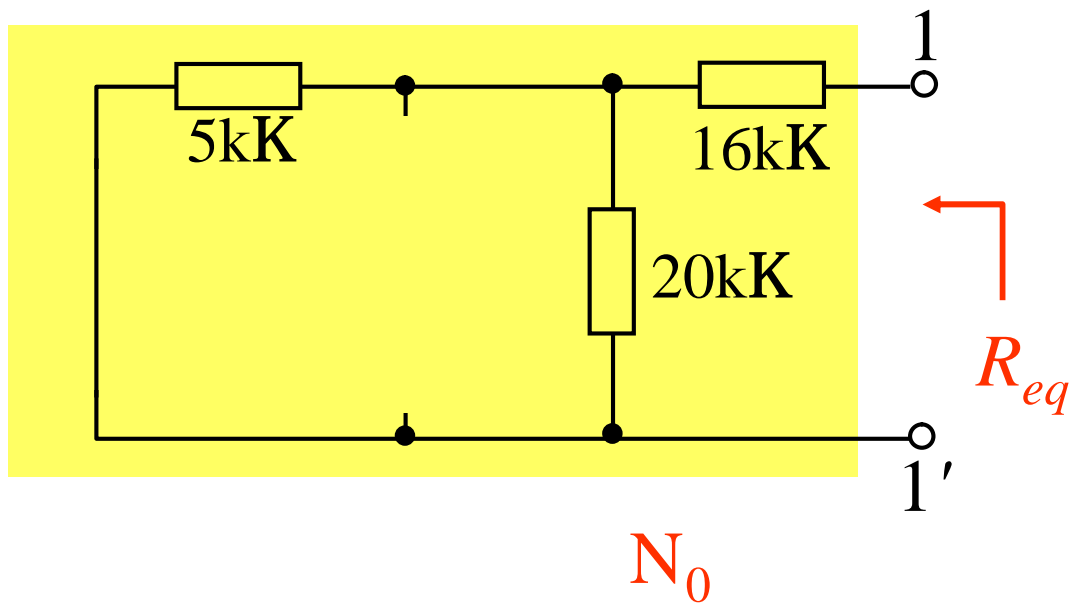

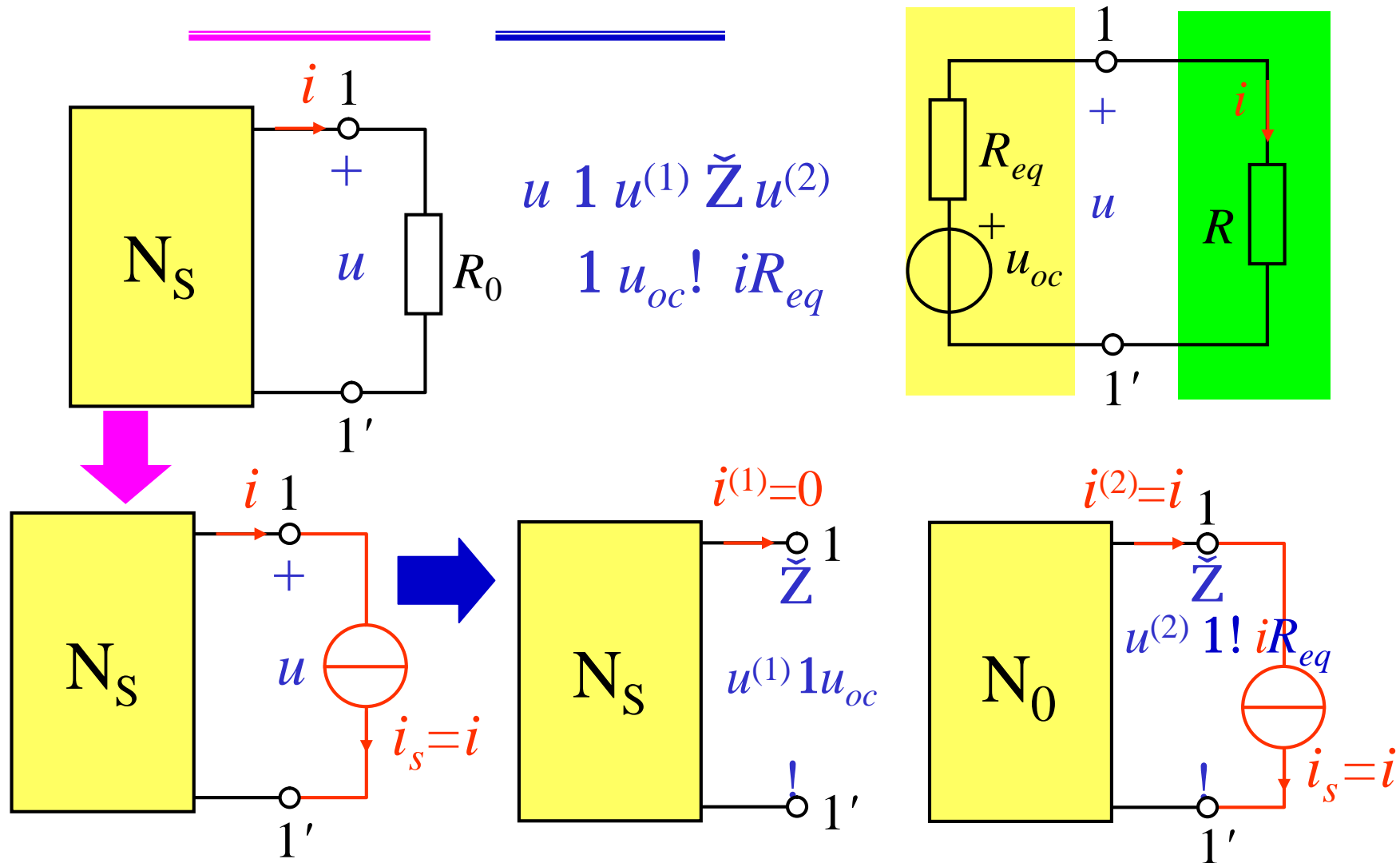
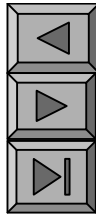

$$u \quad 1 \quad u^{(1)} \quad \tilde{Z} \quad u^{(2)}$$

$$1 \quad u_{oc} \quad i R_{eq}$$

P93 4-5 ¹

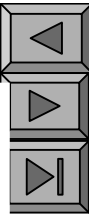
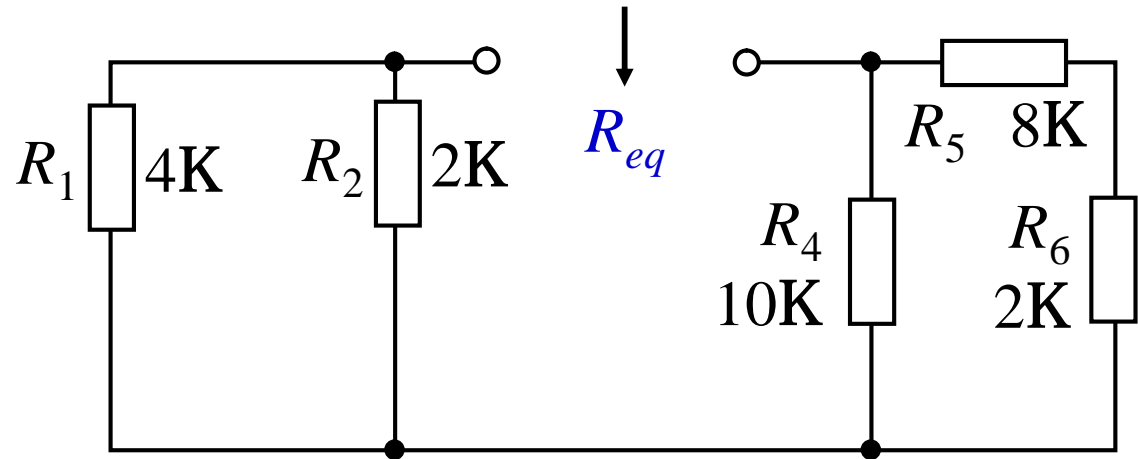

$$u_{oc} = \frac{\frac{u_{s1}}{R_1} + \frac{u_{s2}}{R_2}}{\frac{1}{R_1} + \frac{1}{R_2}}$$

$$R_{eq} = \frac{4 \cdot 2}{4+2} + \frac{10 \cdot (8+2)}{10+(8+2)}$$

$$= 1.33 + 5 = 6.33K$$

$$= \frac{10+20}{0.25+0.5}$$

$$= 40V$$

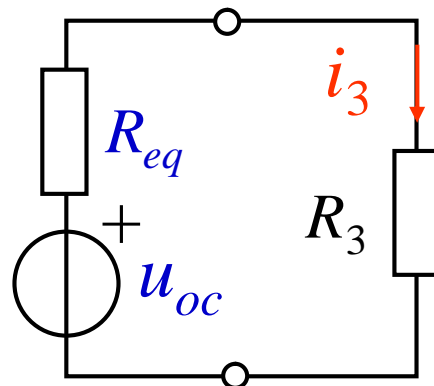

$$i_3 = \frac{40}{6.33+5}$$

$$= 3.53A$$

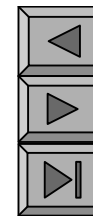

2

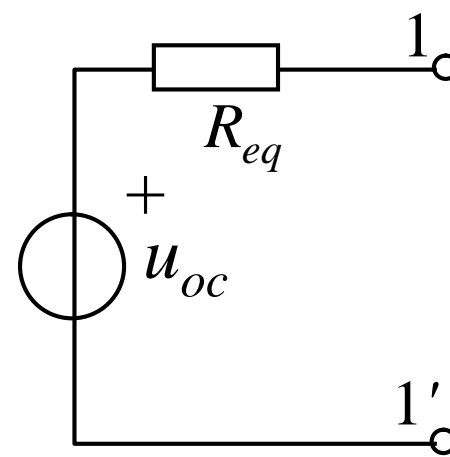
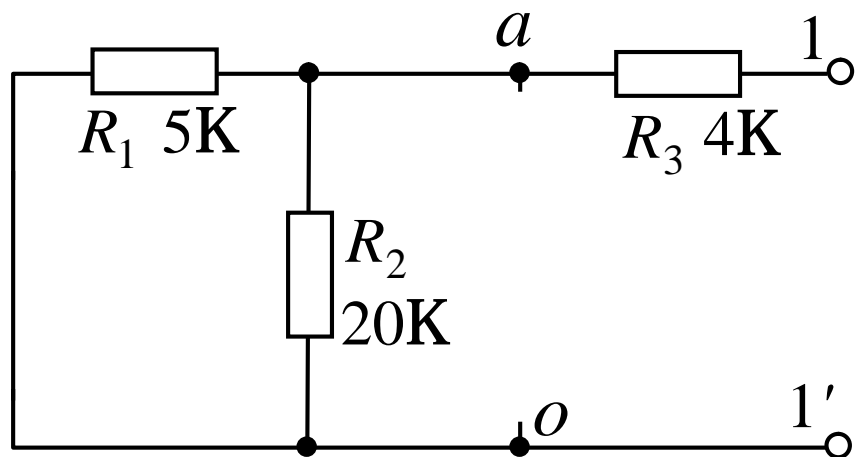

$$u_{oc} = u_{ao}$$

$$u_{oc} = 1 \cdot \frac{\frac{25}{5} \checkmark 3}{\frac{1}{5} \checkmark \frac{1}{20}} = 1 \cdot \frac{100 \checkmark 60}{4 \checkmark 1} = 132V$$

$$R_{eq} = 1 \cdot 4 \checkmark \frac{5 \cdot 20}{5 \checkmark 20} = 1 \cdot 8K$$

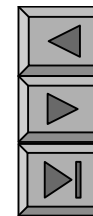

2

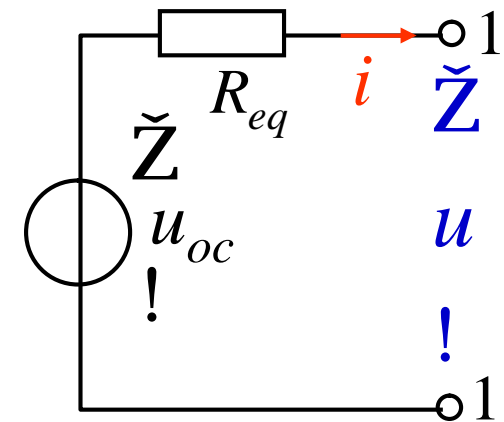
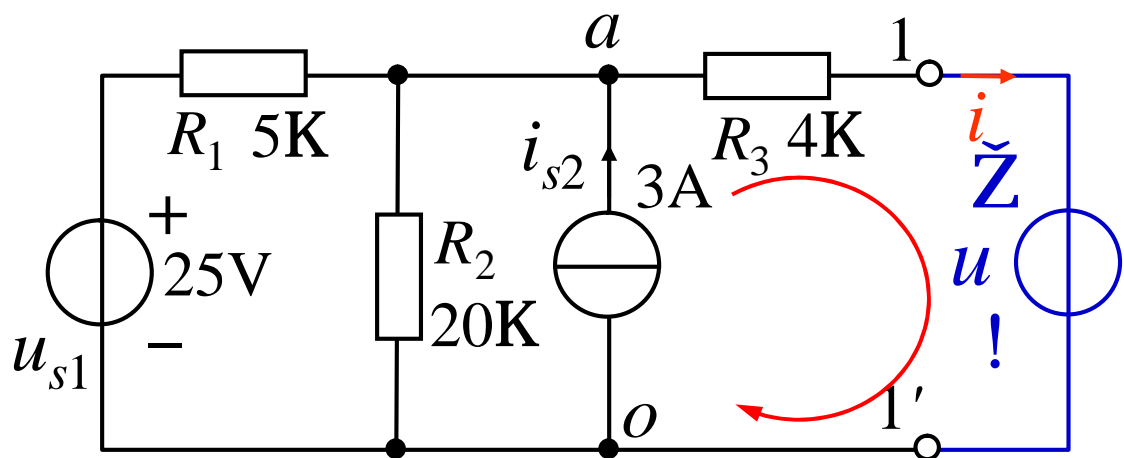

2

u

u

i

$$u_{ao} = \frac{\frac{25}{5} \check{Z} + \check{Z} \frac{u}{4}}{\frac{1}{5} \check{Z} + \frac{1}{20} \check{Z} + \frac{1}{4}} = \frac{u}{2} \check{Z} \cdot 16$$

$$\underline{u = 1 \cdot u_{oc} + R_{eq} \cdot i}$$

$$u_{ao} = 4 \cdot i \cdot \check{Z} \cdot u$$

$$u_{oc} = 132V$$

$$u_{ao} = \underline{u = 1 \cdot 32 + 8 \cdot i}$$

$$R_{eq} = 18K$$

2.

•

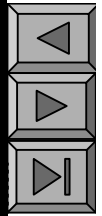
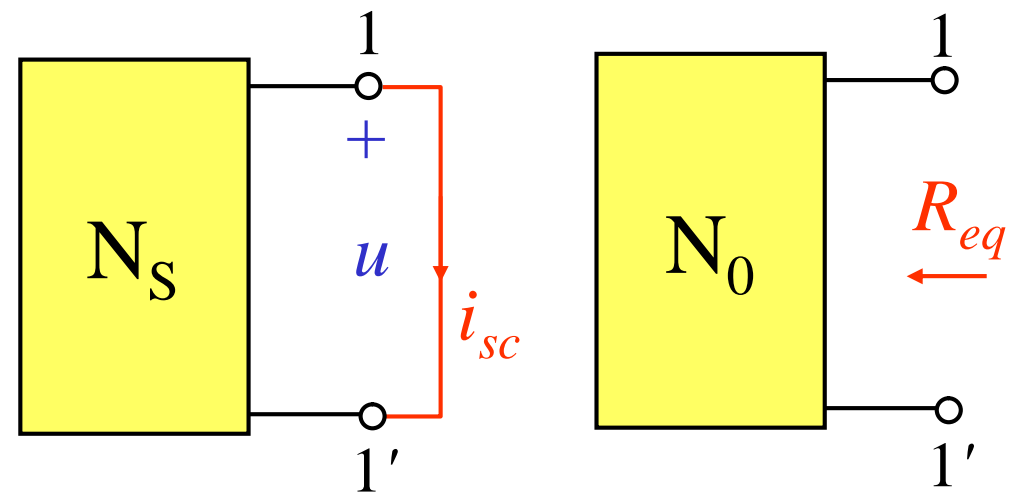
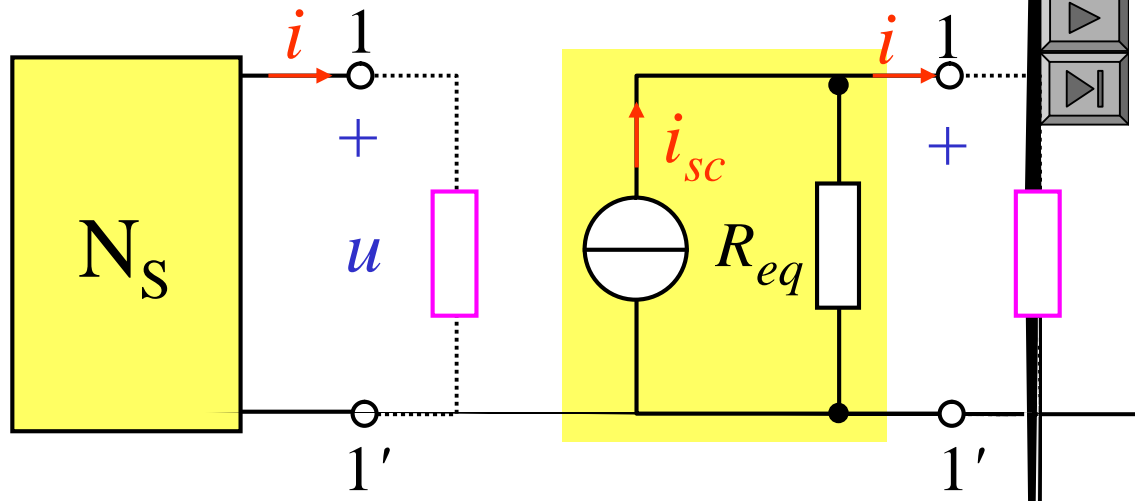
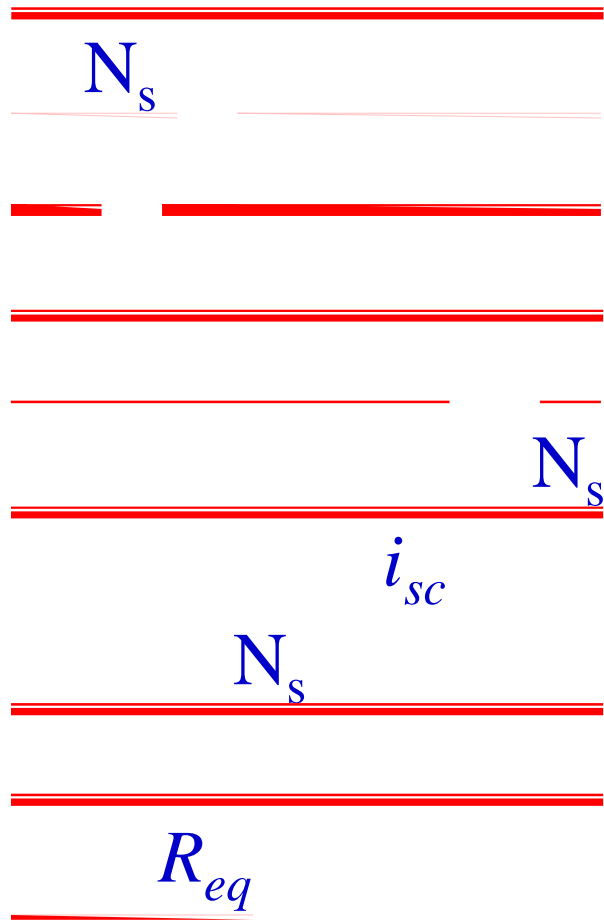



P94 4-7

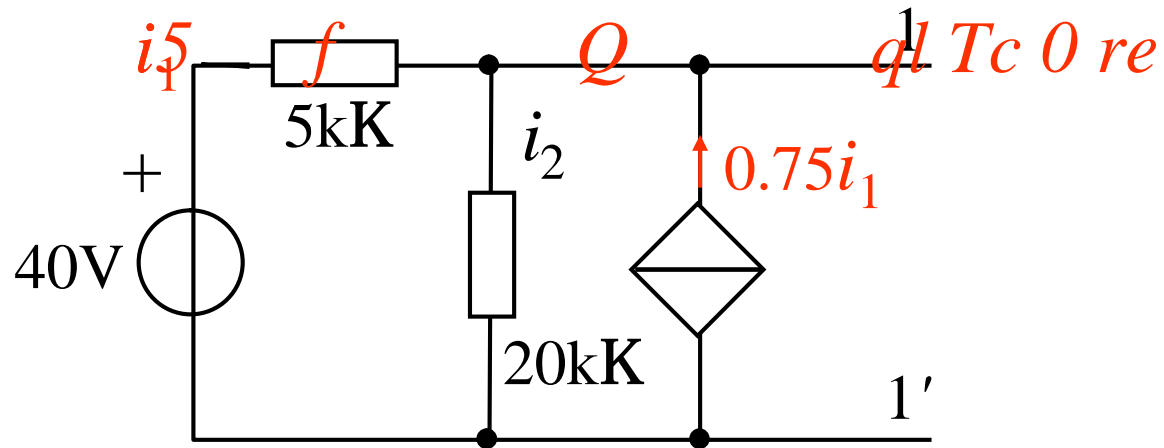

74

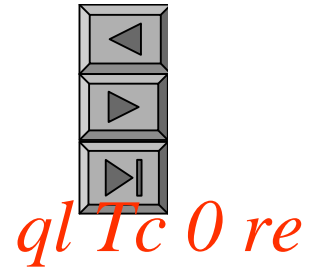

4-4

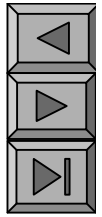
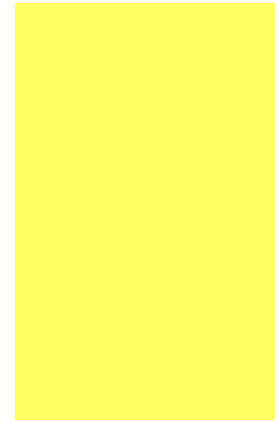
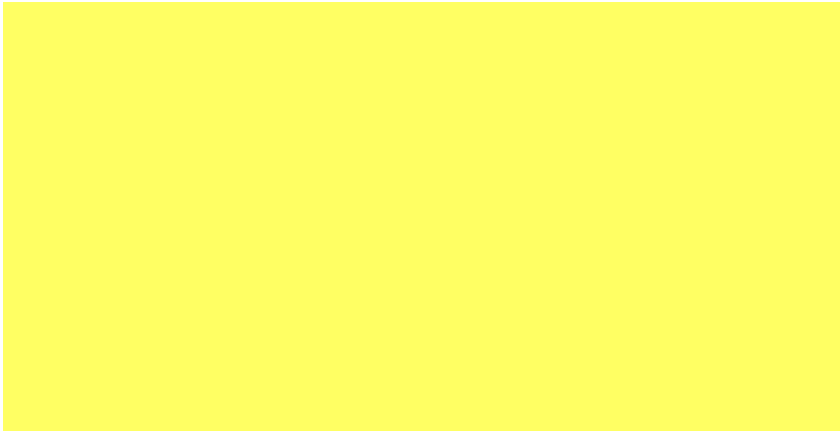

R R_{eq}

1.

$R_{eq} 10$

N_S

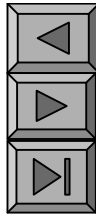
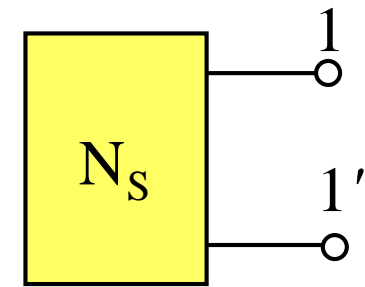

2.

N_S

R_{eq}

$P110$

$4-13$

3.

,

50%

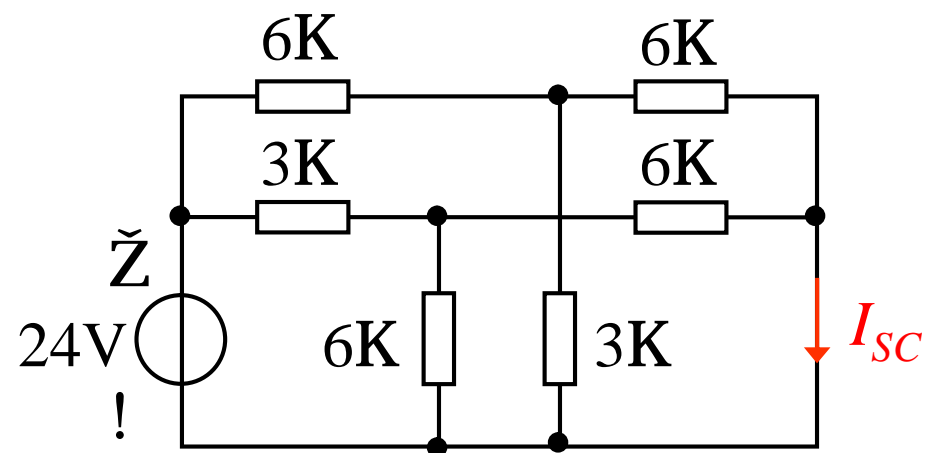
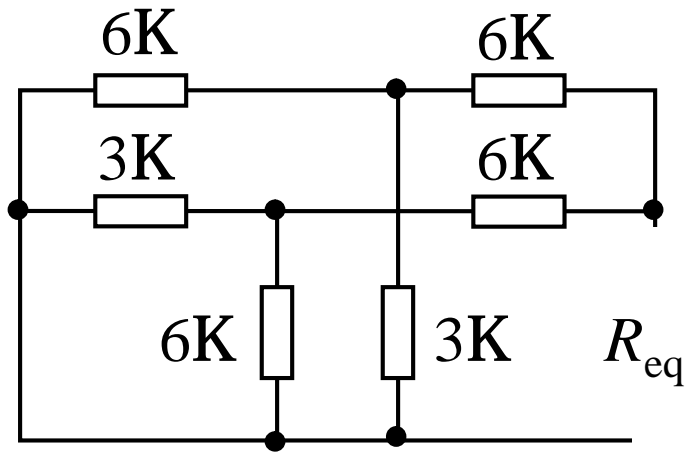
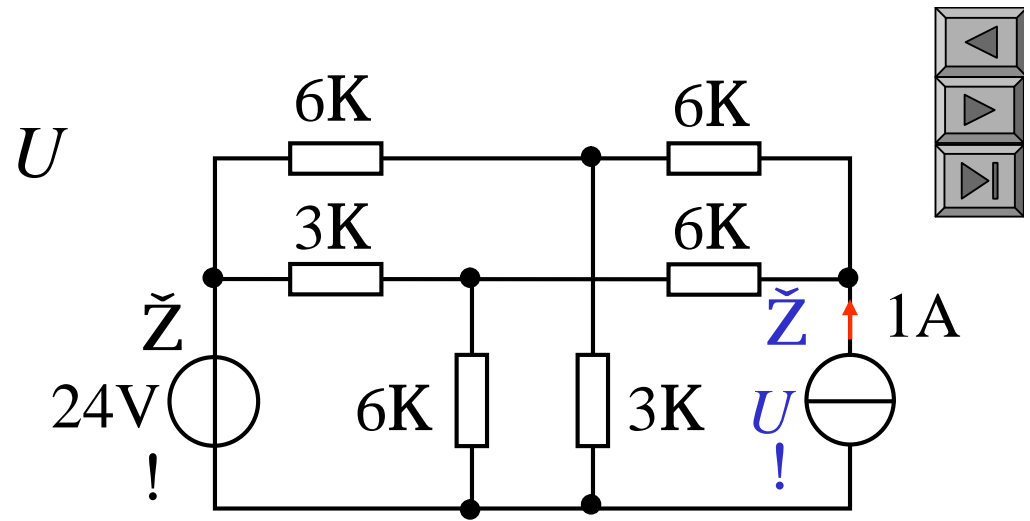

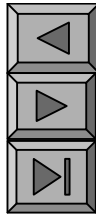

4! 5
 1

n b

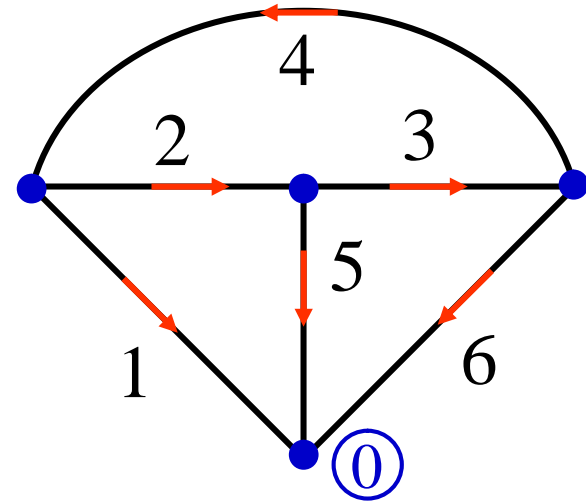

(u_1, u_2, \dots, u_b)

(i_1, i_2, \dots, i_b)

t

$\sum_{k=1}^b u_k i_k = 10$

- $u_{n1} = u_1$
- $u_{n2} = u_5$
- $u_{n3} = u_6$
- $u_2 = u_{n1} \quad u_{n2}$
- $u_3 = u_{n2} \quad u_{n3}$
- $u_4 = u_{n3} \quad u_{n1}$

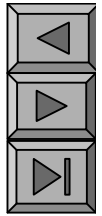

$$\begin{aligned}
 & \overset{6}{u_k i_k} \quad \mathbf{1} u_1 i_1 \check{Z} u_2 i_2 \check{Z} u_3 i_3 \\
 & \overset{k=1}{\check{Z} u_4 i_4 \check{Z} u_5 i_5 \check{Z} u_6 i_6}
 \end{aligned}$$

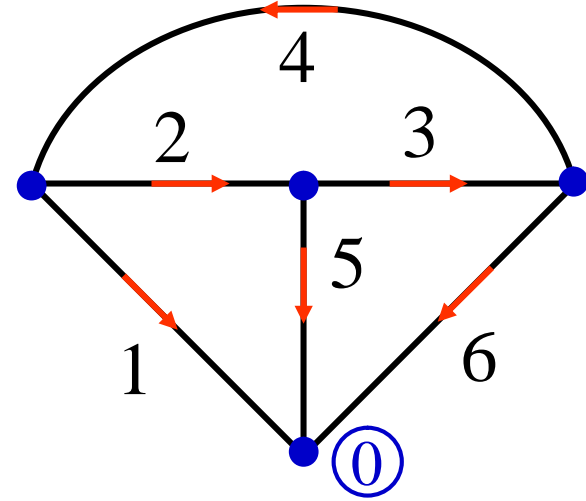

$$\begin{aligned}
 & \mathbf{1} u_{n1} i_1 \check{Z}(u_{n1} ! u_{n2}) i_2 \check{Z}(u_{n2} ! u_{n3}) i_3 \\
 & \check{Z}(u_{n3} ! u_{n1}) i_4 \check{Z} u_{n2} i_5 \check{Z} u_{n3} i_6
 \end{aligned}$$

$$\mathbf{1} u_{n1} \underbrace{(i_1 \check{Z} i_2 ! i_4)}_{\check{Z} u_{n2}} \underbrace{(! i_2 \check{Z} i_3 \check{Z} i_5)}_{\check{Z} u_{n3}}$$

$$\check{Z} u_{n3} \underbrace{(! i_3 \check{Z} i_4 \check{Z} i_6)}_{\mathbf{10}}$$

•

$$\begin{aligned}
 u_{n1} &= u_1 \\
 u_{n2} &= u_5 \\
 u_{n3} &= u_6 \\
 u_2 &= u_{n1} & u_{n2} \\
 u_3 &= u_{n2} & u_{n3} \\
 u_4 &= u_{n3} & u_{n1}
 \end{aligned}$$

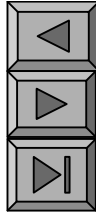

$$\sum_{k=1}^b u_k i_k = 1 \cdot 0$$

$$\begin{matrix} u_k & i_k \\ u_k & i_k \end{matrix}$$

$$\begin{matrix} \checkmark u_k i_k \\ ! u_k i_k \end{matrix}$$

1

•

_____ (power theorem)

•

1

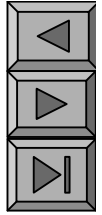

• 2

n b

$$\begin{aligned} & (i_1, i_2, \dots, i_b) & (u_1, u_2, \dots, u_b) \\ & (\hat{i}_1, \hat{i}_2, \dots, \hat{i}_b) & (\hat{u}_1, \hat{u}_2, \dots, \hat{u}_b) \end{aligned}$$

b

t

$$\begin{aligned} & \sum_{k=1}^b \hat{u}_k i_k \mathbf{1} \cdot \mathbf{0} \\ & k=1 \end{aligned}$$

$$\begin{aligned} & \sum_{k=1}^b u_k \hat{i}_k \mathbf{1} \cdot \mathbf{0} \\ & k=1 \end{aligned}$$

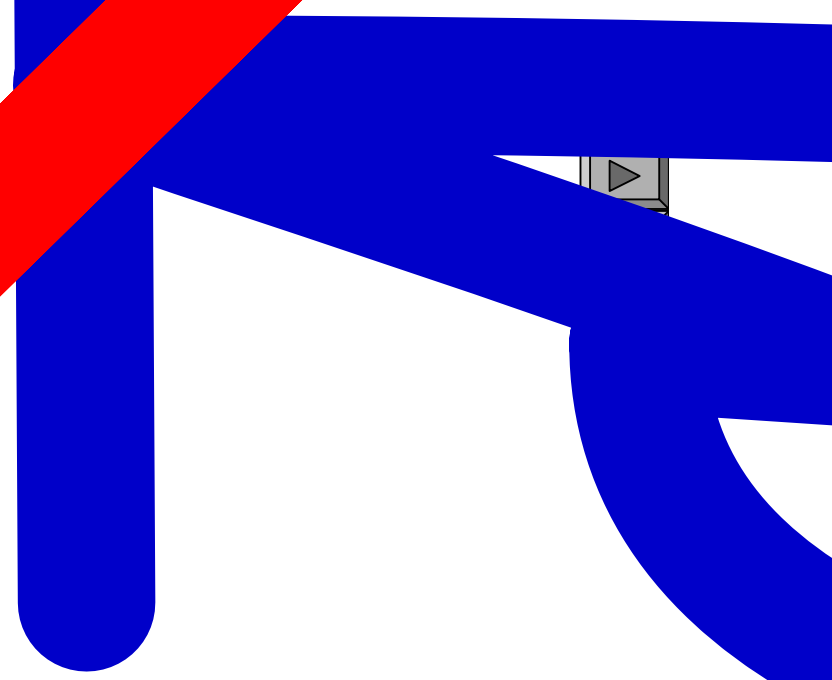
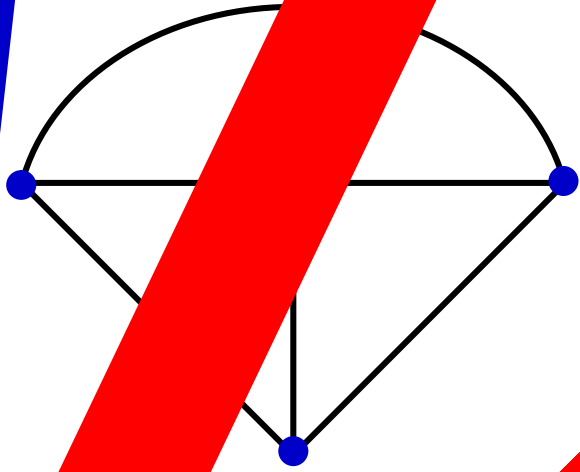

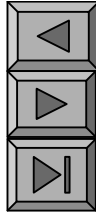

$$\begin{matrix} b \\ \hat{u}_k i_k \mathbf{1} \cdot \mathbf{0} \\ k=1 \end{matrix}$$

$$\begin{matrix} b \\ u_k \hat{i}_k \mathbf{1} \cdot \mathbf{0} \\ k=1 \end{matrix} \longrightarrow$$

$$\hat{u}_k \quad i_k$$

“ $\check{Z} \hat{u}_k i_k$ ”

“ $! \hat{u}_k i_k$ ”

-
-
-

(quasi-power theorem)

2

2

$$\begin{array}{c}
 \begin{array}{c}
 \overset{2}{u_s} \overset{\hat{i}_1}{\check{Z}} \overset{u}{\hat{i}_2} \check{Z} \overset{b}{u_k} \overset{\hat{i}_k}{1} \overset{0}{0} \\
 \overset{b}{k=3}
 \end{array} \\
 \begin{array}{c}
 \overset{\hat{u}}{i_1} \check{Z} \overset{\hat{u}_s}{i_2} \check{Z} \overset{b}{\hat{u}_k} \overset{i_k}{1} \overset{0}{0} \\
 \overset{b}{k=3}
 \end{array} \\
 \begin{array}{c}
 3 \quad b
 \end{array}
 \end{array}$$

$$u_k = R_k i_k \quad \hat{u}_k = R_k \hat{i}_k$$

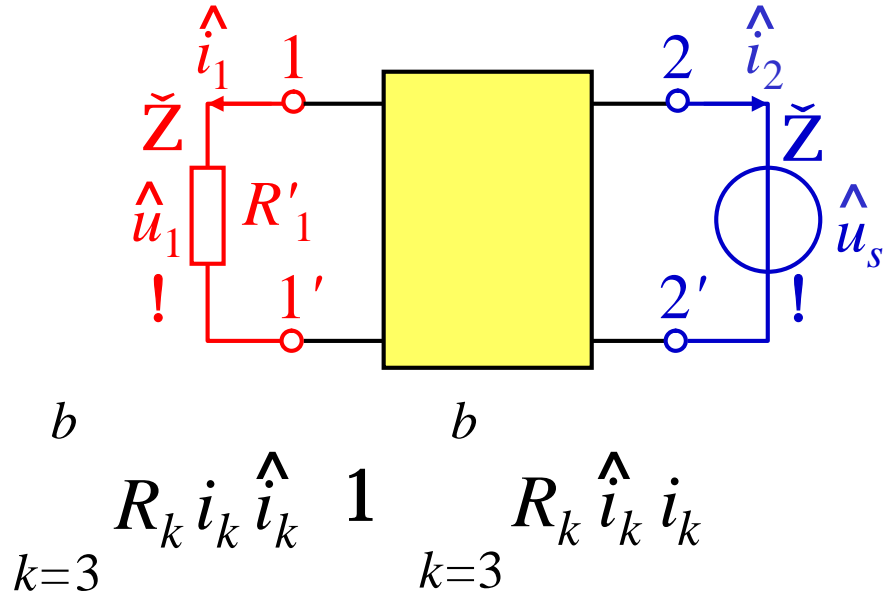
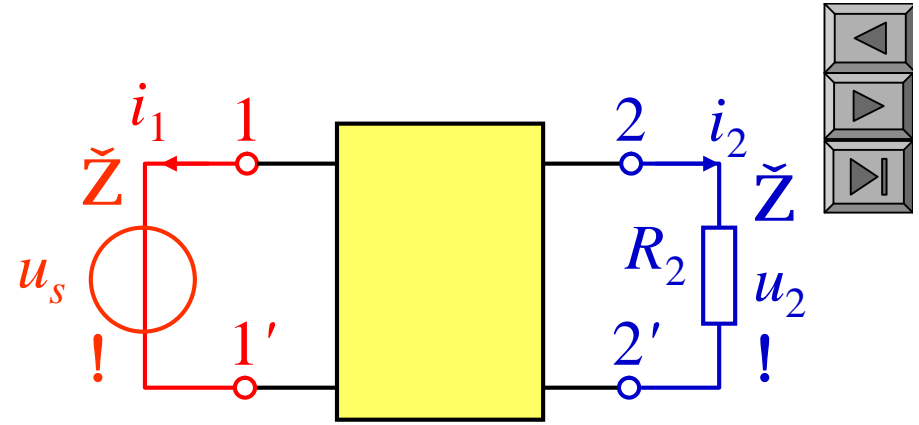

$$\underline{\underline{u_s \hat{i}_1 \check{Z} u_2 \hat{i}_2 \quad 1 \quad \hat{u}_1 i_1 \check{Z} \hat{u}_s i_2}}$$

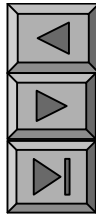

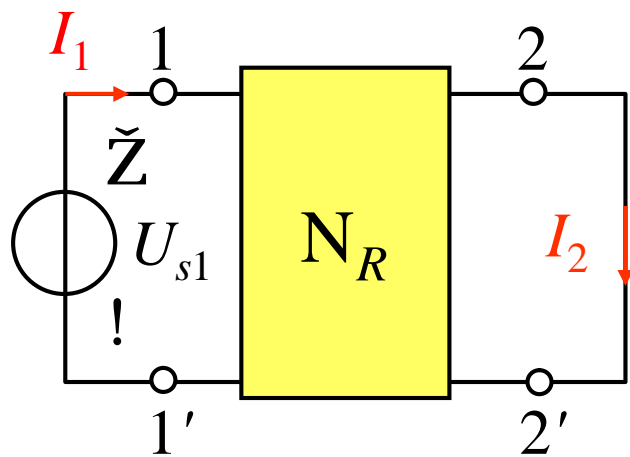
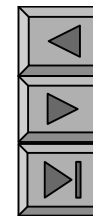

$$\begin{array}{l}
 N_R \\
 U_{s1} \ 120V \\
 I_2 \ 12A \\
 3K \\
 \hat{I}_1 \ 1.4A \\
 I_1 \ 110A \\
 U_{s2} \ 2 \ 2' \\
 1 \ 1' \\
 U_{s2} \ 1
 \end{array}$$

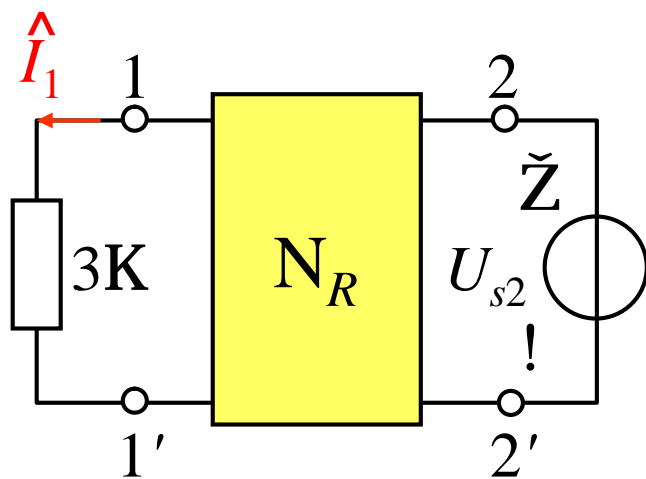

$$\begin{array}{l}
 N_R \\
 2 \\
 U_{s1} \ \hat{I}_1 \ \checkmark \ 0 \\
 I_2 \ 1 \ U_{s2} \ I_2 - (3 \hat{I}_1) \ I_1 \\
 20 \ 4 \ 1 \ 2 \ U_{s2} \ ! \ 3 \ 4 \ 10 \\
 U_{s2} \ 1100V
 \end{array}$$

4 6

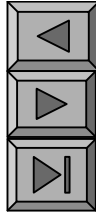

$$R_{ik}^{-1} R_{ki} = G_{ik}^{-1} G_{ki}$$

— (reciprocity)

3.

$$\begin{array}{c}
 2 \\
 u_s \hat{i}_1 \check{Z} u_2 \hat{i}_2 \quad 1 \hat{u}_1 i_1 \check{Z} \hat{u}_s i_2 \\
 R'_1 \quad 1 \quad R_2 \quad 1 \quad 0 \\
 u_2 \quad 1 \quad 0 \quad \hat{u}_1 \quad 1 \quad 0 \\
 \hline
 \frac{i_2}{u_s} \quad 1 \quad \frac{\hat{i}_1}{\hat{u}_s} \\
 u_s \quad 1 \quad \hat{u}_s \quad i_2 \quad 1 \quad \hat{i}_1
 \end{array}$$

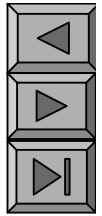
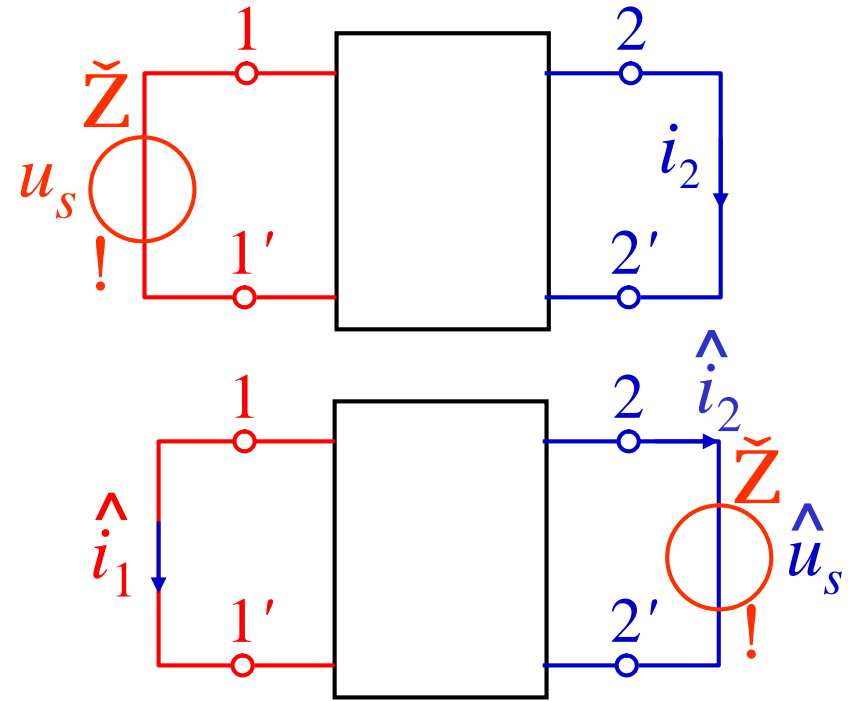

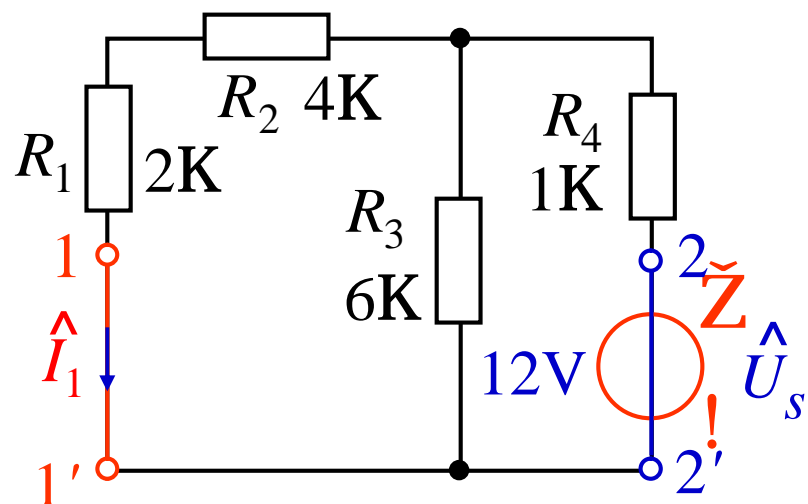
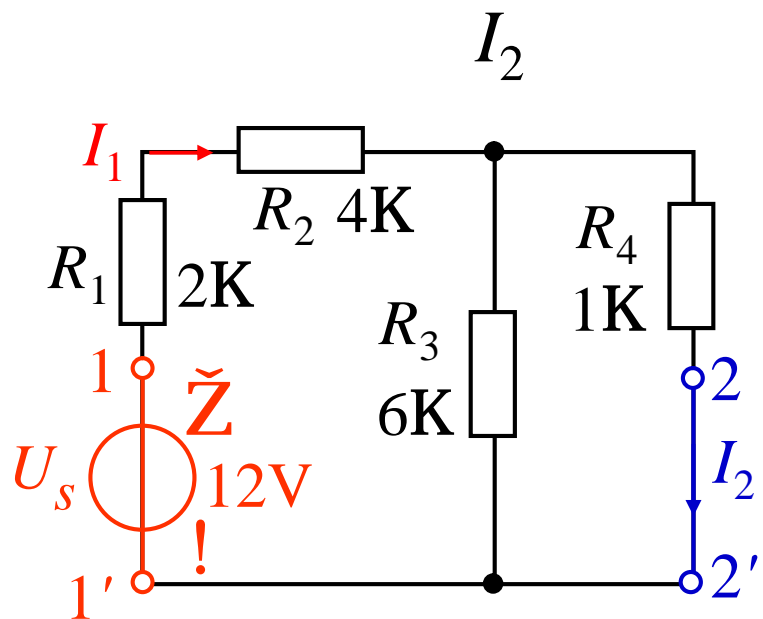
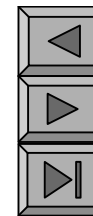

$$I_1 = \frac{12}{4 + \frac{6 \cdot 1}{6 + 1}} = \frac{12}{\frac{48}{7}} = \frac{7}{4} \text{ A}$$

$$I_2 = \frac{6}{6 + 1} \cdot \frac{7}{4} = 1.5 \text{ A}$$

$$\hat{U}_s = U_s = 12 \text{ V}$$

$$I_2 = \hat{I}_1$$

$$R_1 + R_2 = 6 \text{ K} + R_3$$

$$I_2 = \hat{I}_1 = \frac{12}{\frac{6}{2} + 1} = 1.5 \text{ A}$$

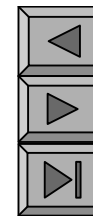

•

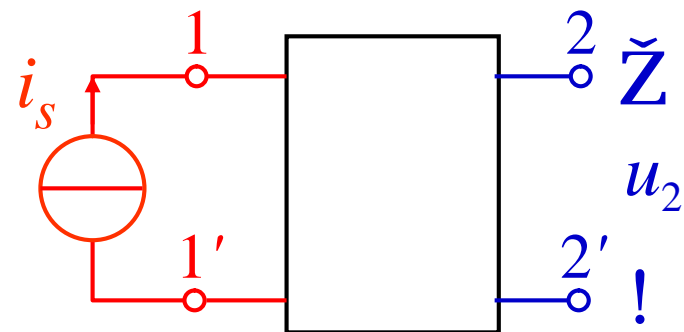

•

2

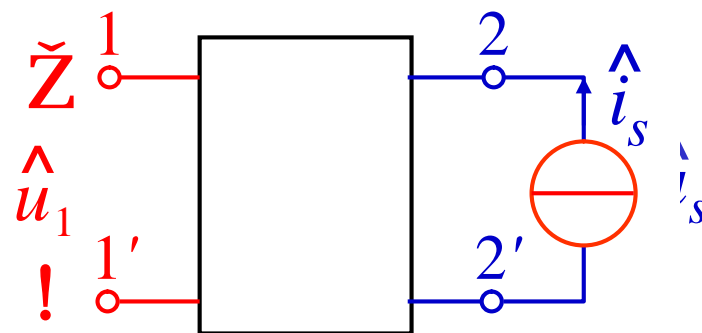

$$i_s \hat{u}_1 \check{Z} \quad u_2 \hat{i}_s \check{Z}$$

$$\frac{u_2}{i_s} \quad \frac{\hat{u}_1}{\hat{i}_s} \Rightarrow \begin{matrix} i_s & \hat{i}_s \\ u_2 & \hat{u}_1 \end{matrix}$$

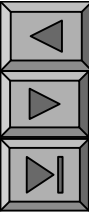

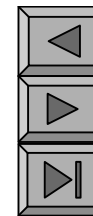

2

$$! i_s \hat{u}_1 \check{Z} i_2 \hat{u}_s \mathbf{1} \cdot \mathbf{0} \check{Z} \mathbf{0}$$

$$\frac{i_2}{i_s} \mathbf{1} \frac{\hat{u}_1}{\hat{u}_s}$$

$$i_s \mathbf{1} \hat{u}_s$$

$$i_2 \mathbf{1} \hat{u}_1$$

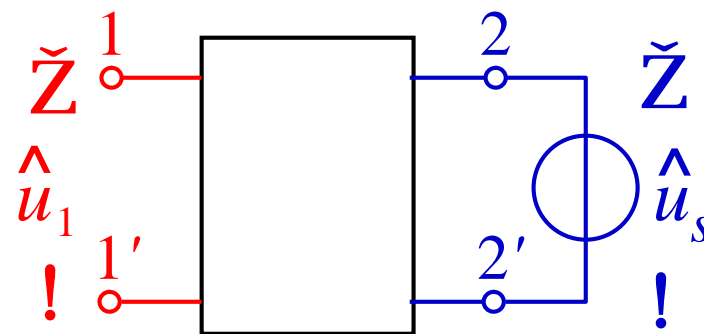
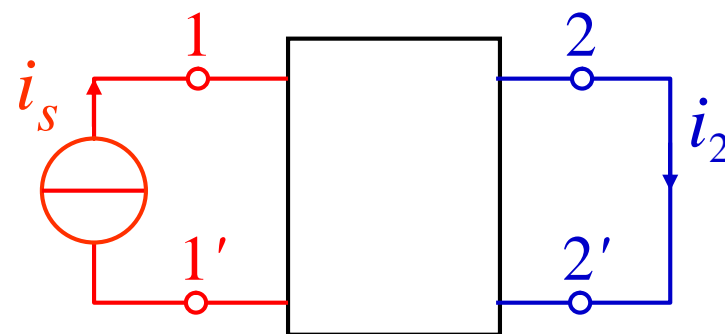

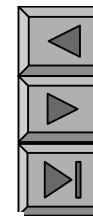

1.

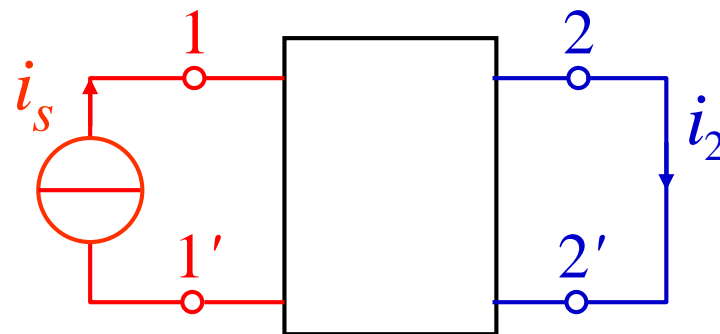

2.

()

()

3.

N_R $U_{s1} 120V$
 $I_1 110A$ $I_2 12A$ U_{s1}
 $2 2'$ $1 1'$
 $3K$ $\hat{I}_1 1$

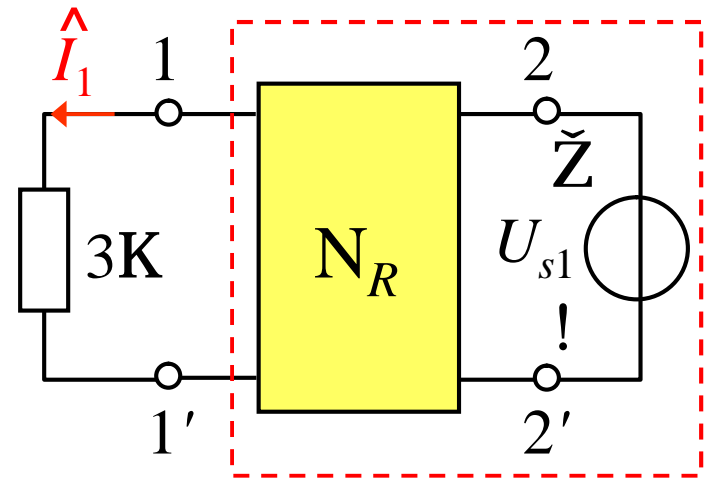
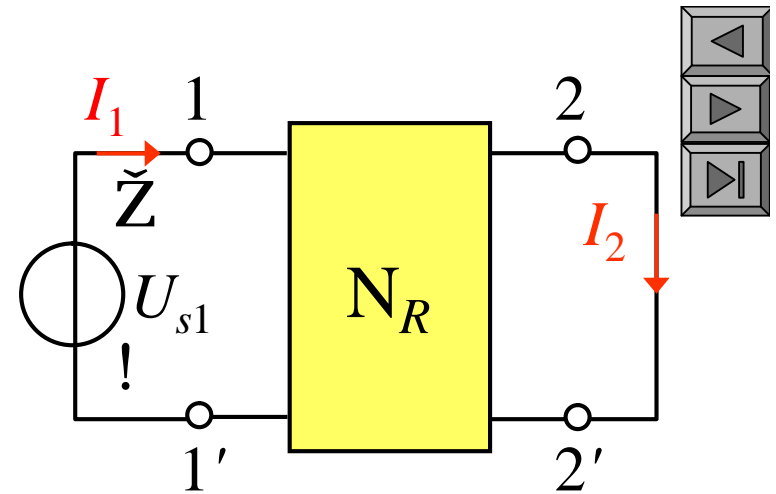
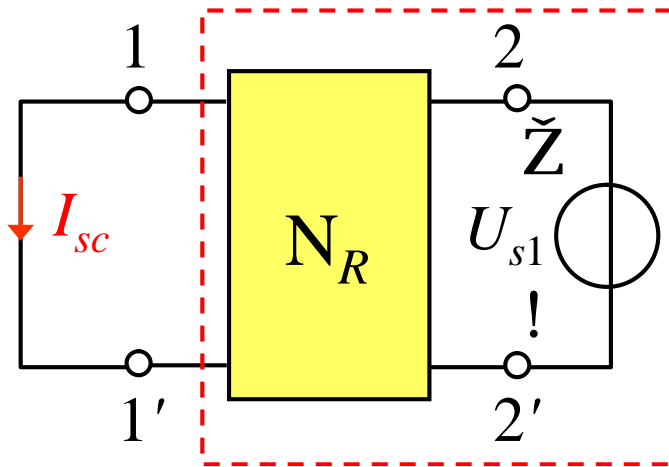

$I_{sc} 1 I_2 1 2A$

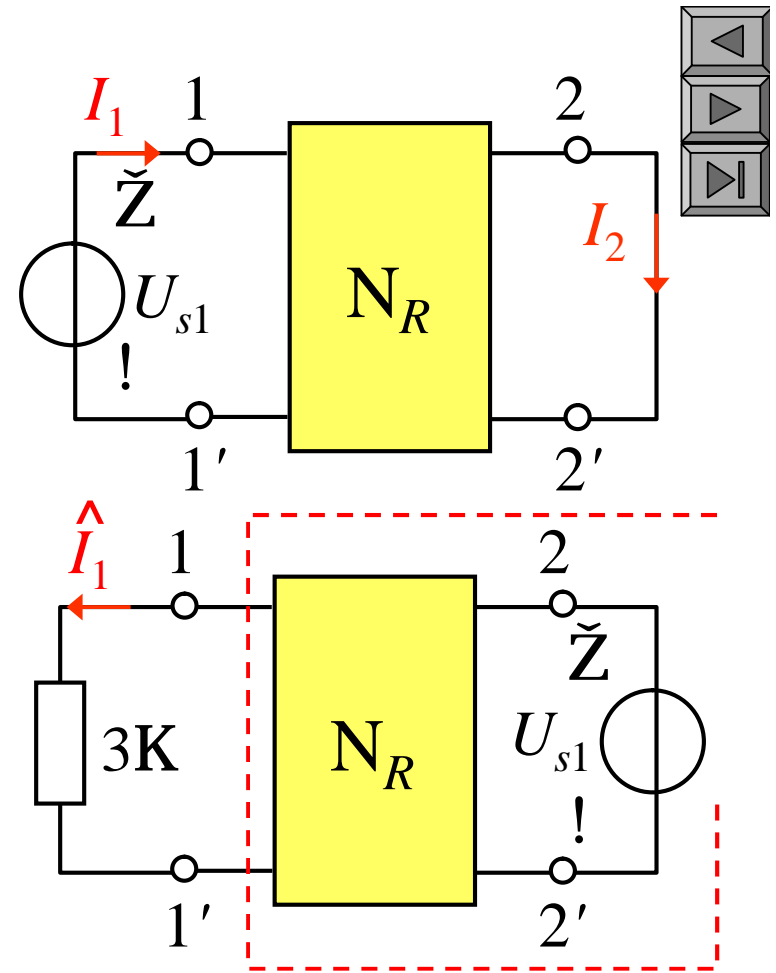
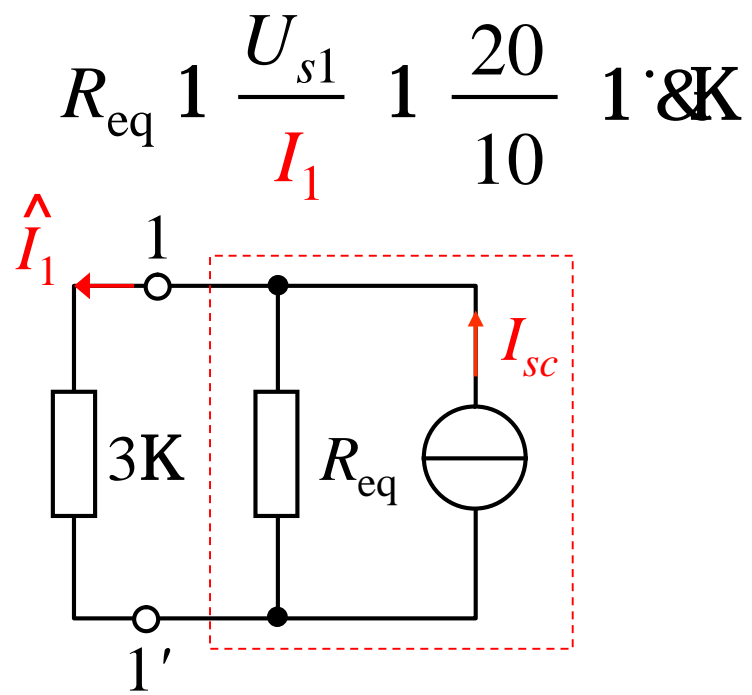

4!7

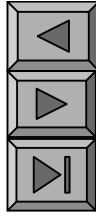

“

”

“

”

N									

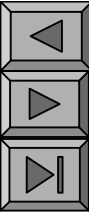

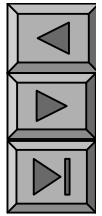

• n

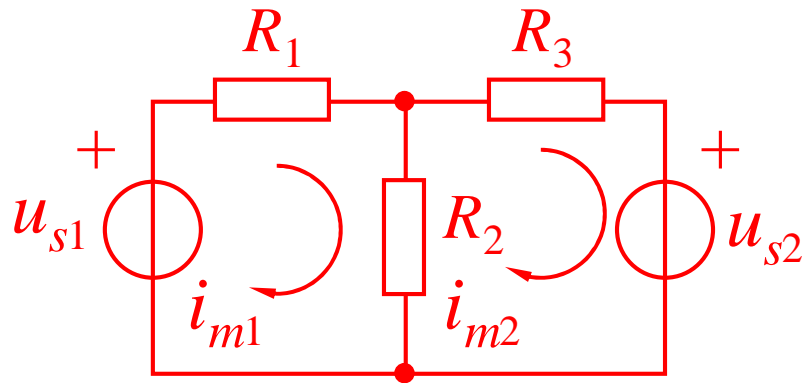

$$(R_1 + R_2) i_{m1} - R_2 i_{m2} = u_{s1}$$

$$R_2 i_{m1} + (R_2 + R_3) i_{m2} = u_{s2}$$

n

o

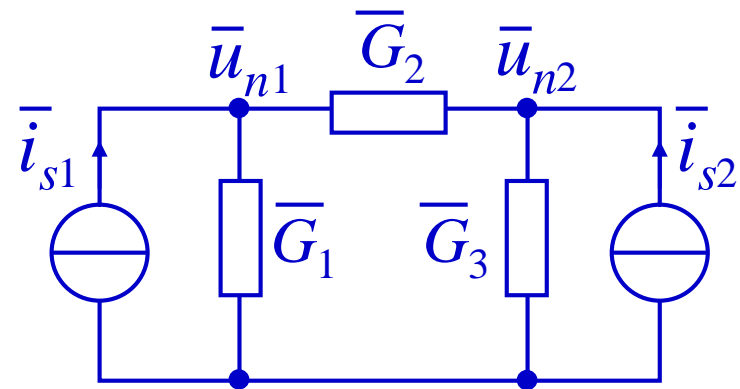

$$(\bar{G}_1 + \bar{G}_2) \bar{u}_{n1} - \bar{G}_2 \bar{u}_{n2} = \bar{i}_{s1}$$

$$\bar{G}_2 \bar{u}_{n1} + (\bar{G}_2 + \bar{G}_3) \bar{u}_{n2} = \bar{i}_{s2}$$

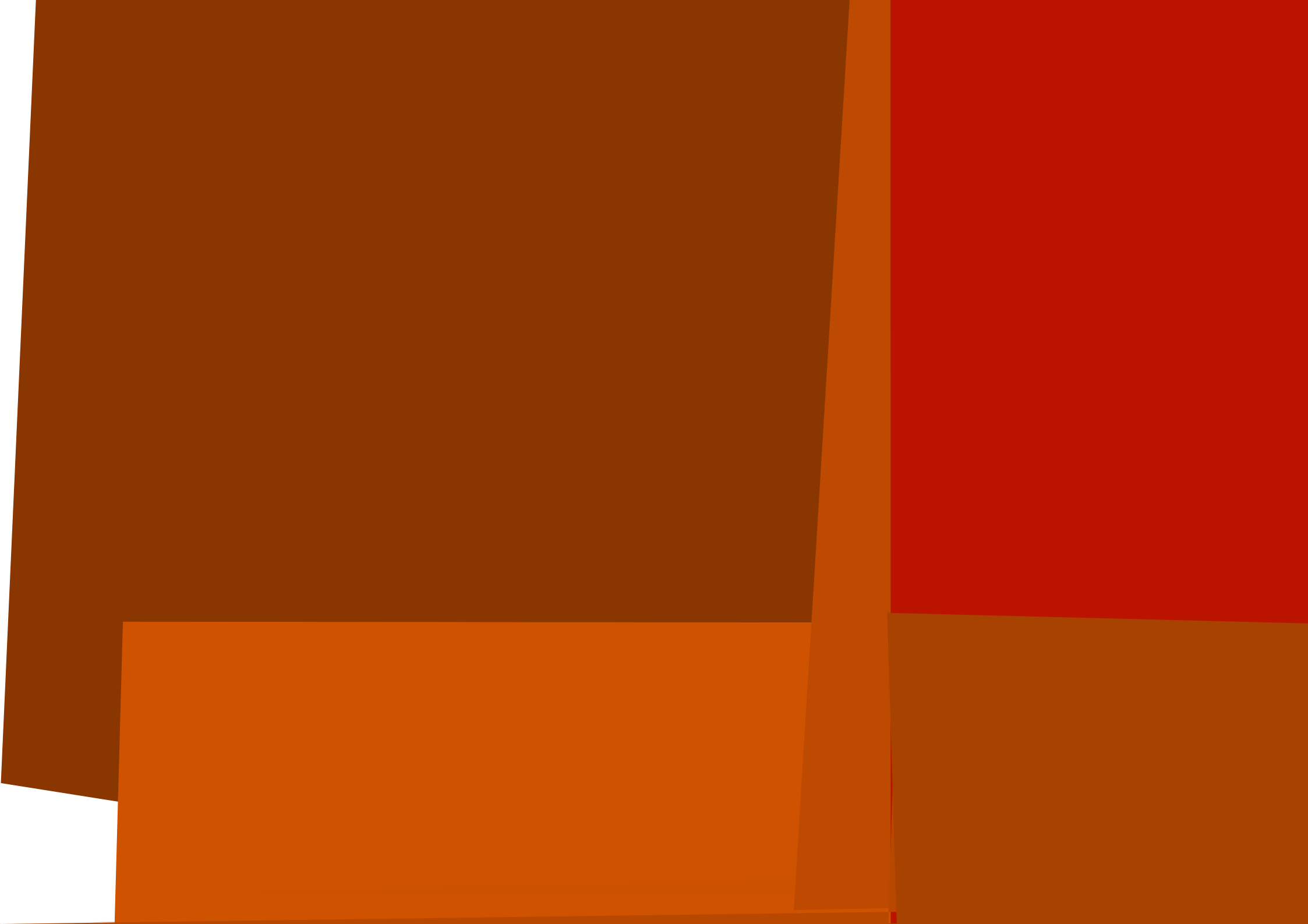

U_{ab} (P49 2-8)

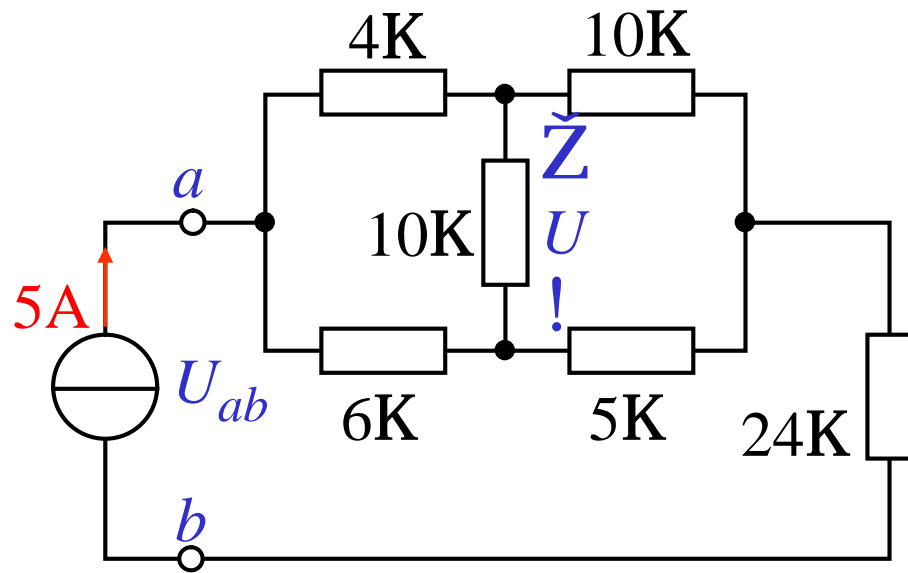
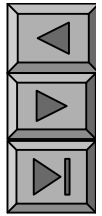

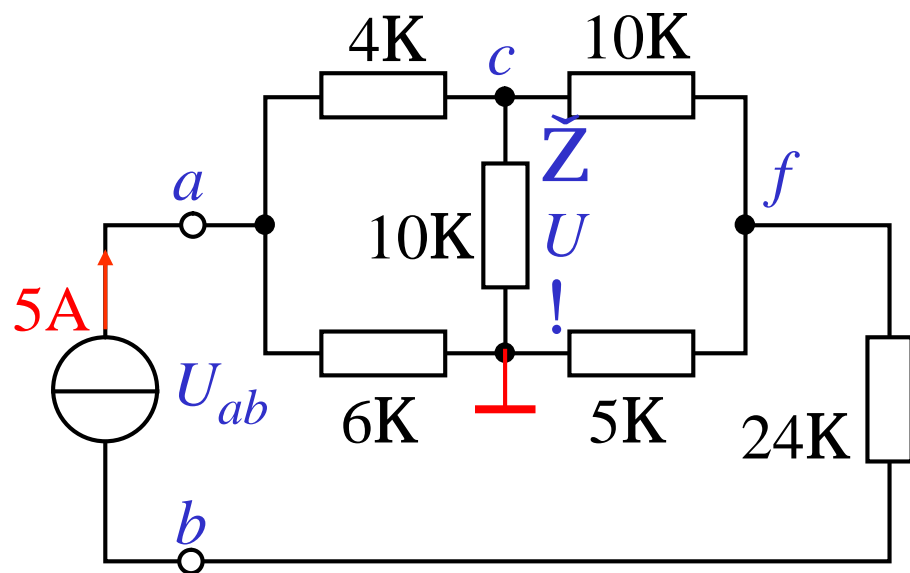
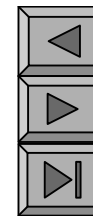

$$U_a = 115\text{V}, \quad U_c = 15\text{V},$$

$$U_f = 115\text{V}$$

$$U_{ab} = 115\text{V} - U_a - U_c - U_f = 115\text{V} - 115\text{V} - 15\text{V} - 115\text{V} = -115\text{V}$$

$$U_a - U_f = 115\text{V} - 115\text{V} = 0\text{V}$$

$$U_c = 15\text{V}$$

$$\begin{cases} \left(\frac{1}{4} + \frac{1}{6}\right) U_a - \frac{1}{4} U_c = 5 \\ -\frac{1}{4} U_a + \left(\frac{1}{4} + \frac{1}{10} + \frac{1}{10}\right) U_c - \frac{1}{10} U_f = 5 \\ -\frac{1}{10} U_c + \left(\frac{1}{5} + \frac{1}{10}\right) U_f = 5 \end{cases}$$

U U_{ab} (P49 2-8)

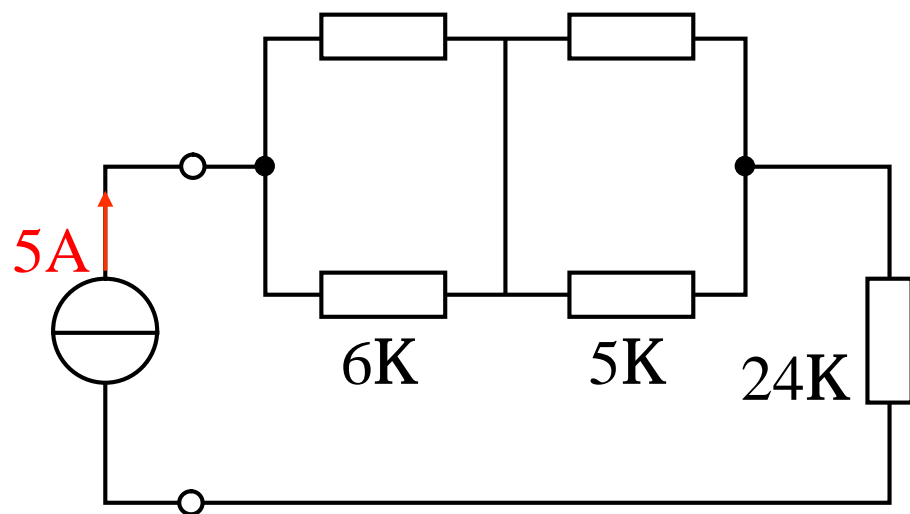

()

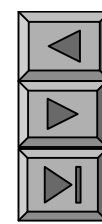

P49 2-8)

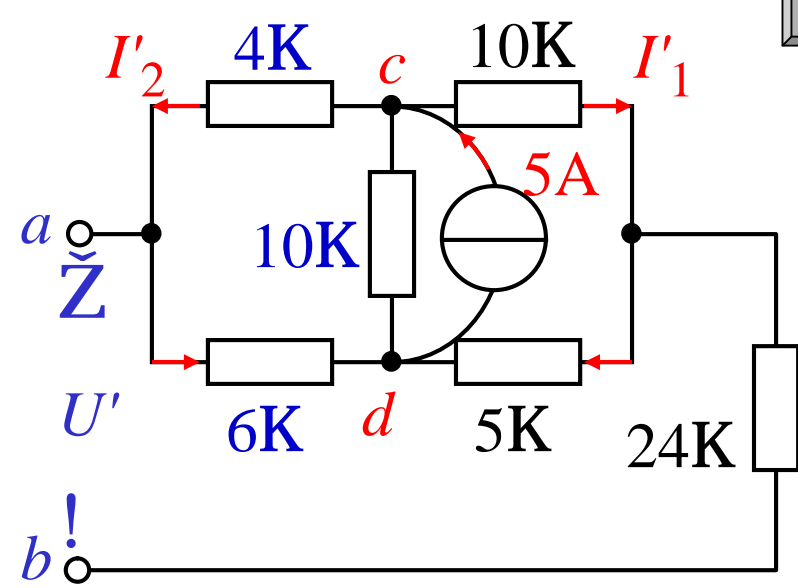
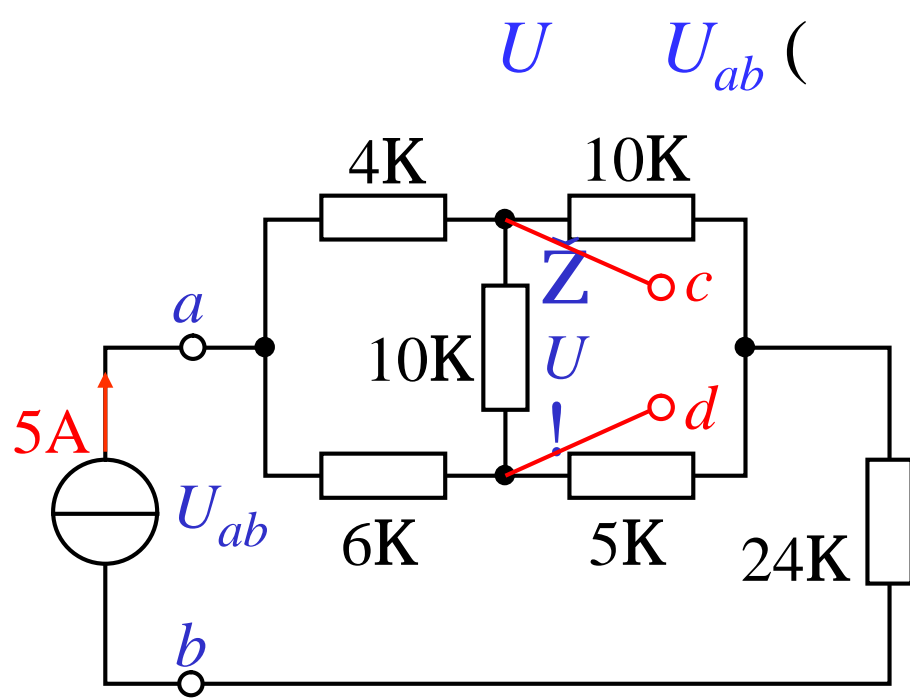

U c d

$$I'_1 = \frac{5}{(10+5)+5} = \frac{5}{20} = 0.25 \text{ A}$$

$$I'_2 = \frac{5-1.25}{2} = \frac{3.75}{2} = 1.875 \text{ A}$$

U

$$U' = \frac{3.75}{2} \times 10 = 18.75 \text{ V}$$

$$U = 7.5 \times 2 = 15 \text{ V}$$

$U = U' = 15 \text{ V}$

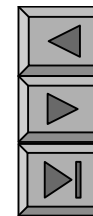

U_{ab} (P49 2-8)

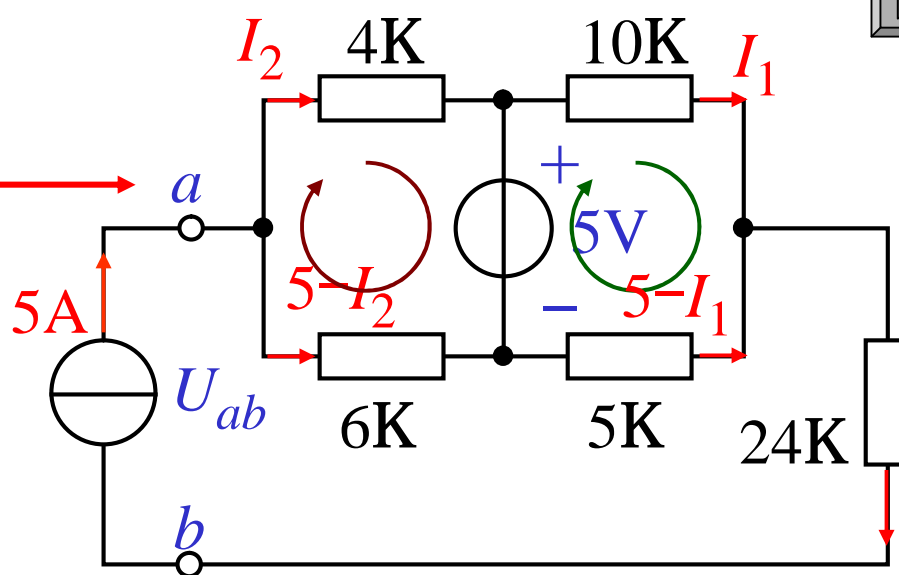
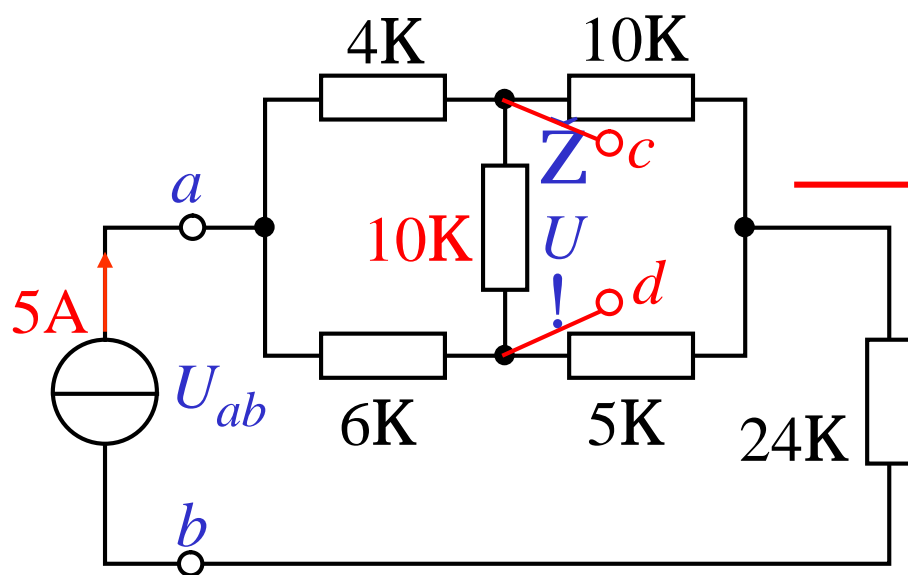

$U_{ab} = 5V$

10K

$4I_2 + 6I_2 + I_2 = 5$

$I_2 = 12.5A$

$10I_1 + 5(5 - I_1) = 15$

$I_1 = 2A$

$U_{ab} = 14I_2 + 10I_1 + 24 \cdot 5$

$= 110 + 20 + 120 = 150V$