

8



8.1

8.2

8.3

8.4

8.5



8

1.

2.

3.

4.

5.

;

;

;



8



8.1

8.1.1

1.

380V 5.5kW

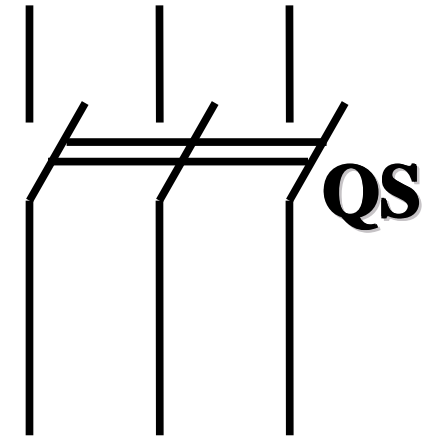

1.

/

2.

/

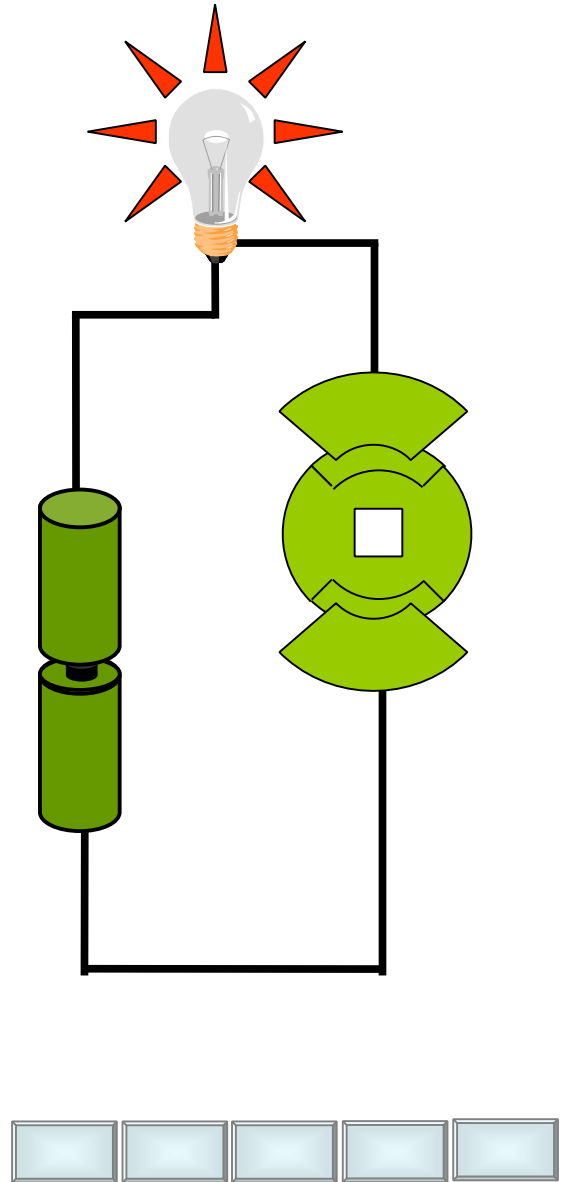

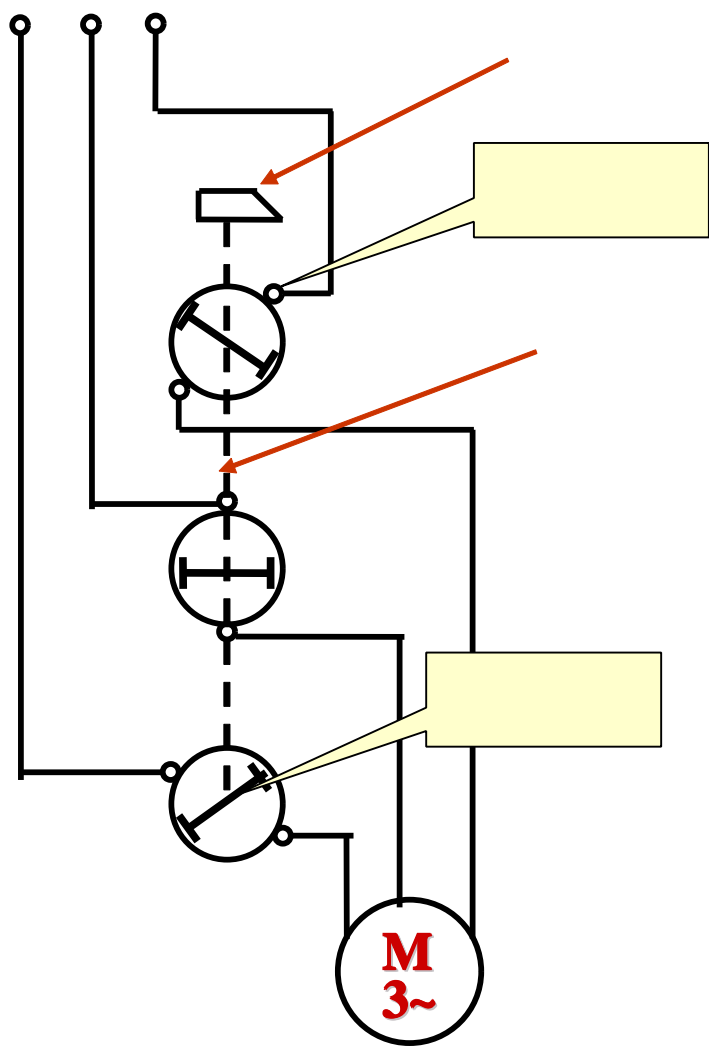

8.1.2

1.

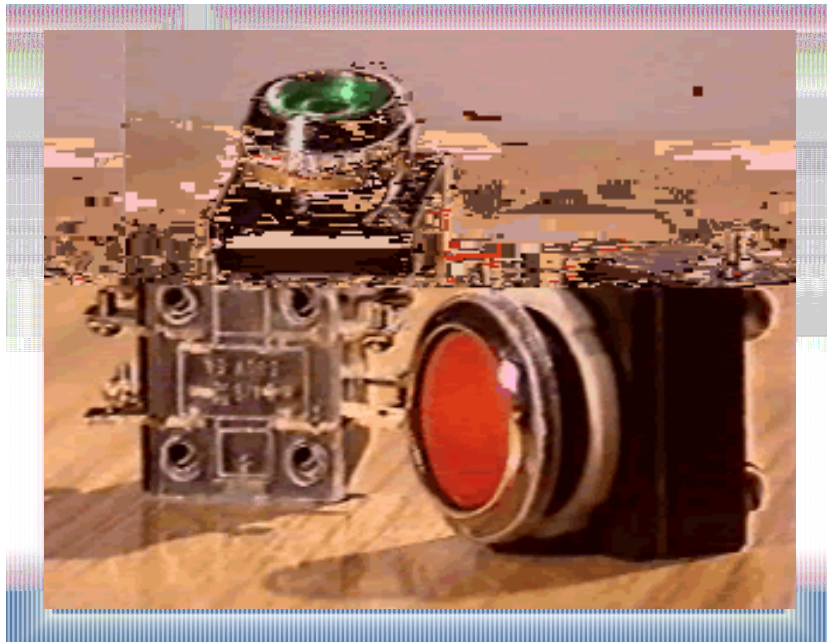

(a)

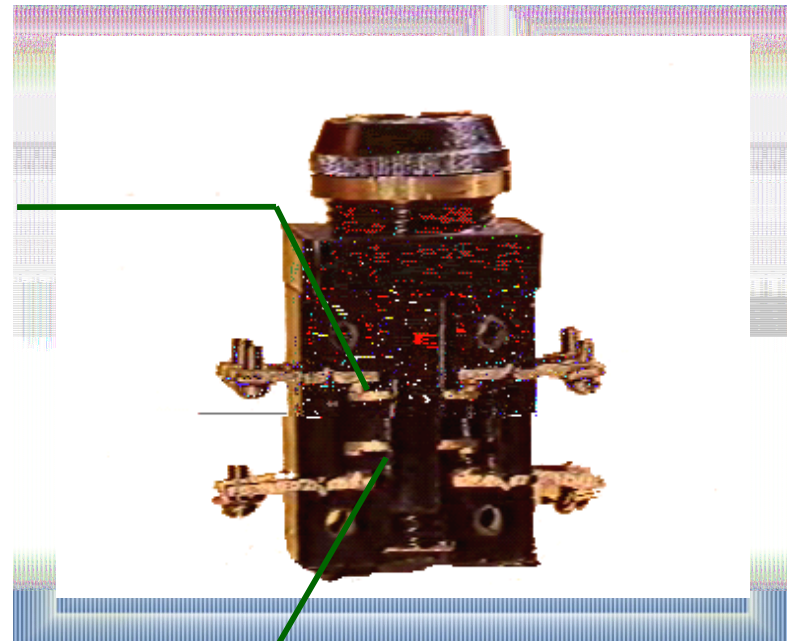

(b)



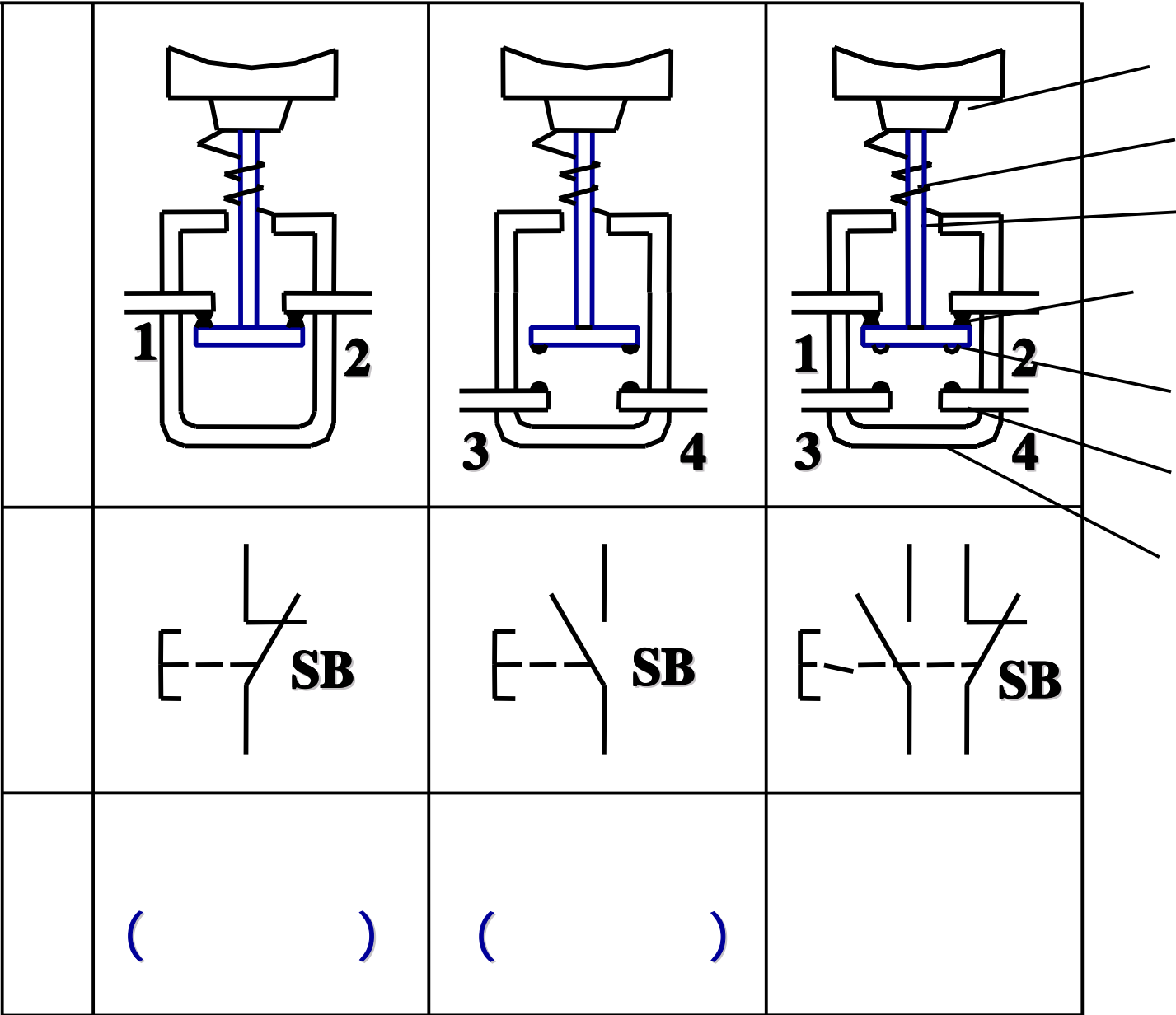

2.

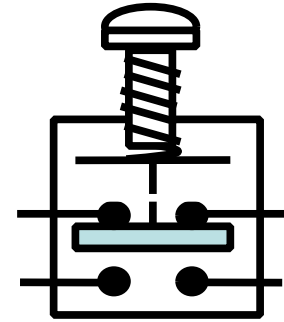

8.1.3

1.

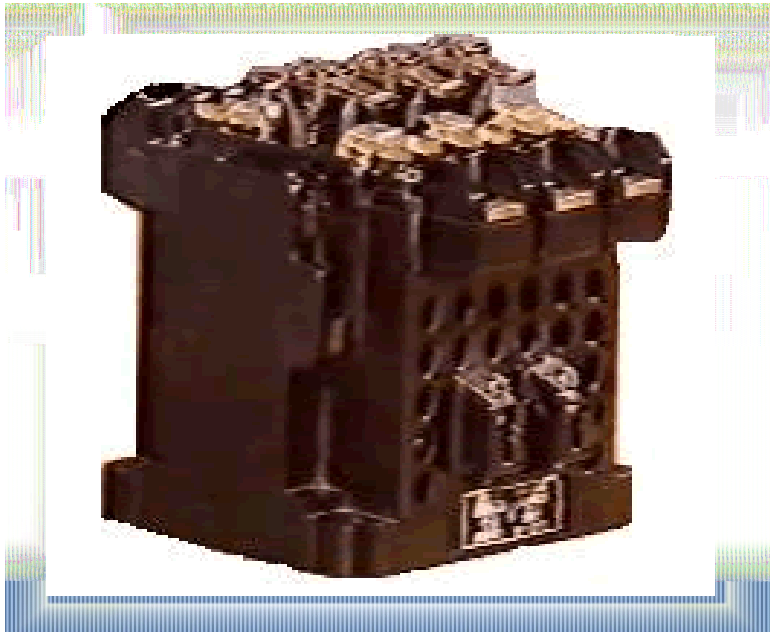

(a)



(b)

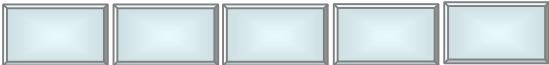

2.

1



2

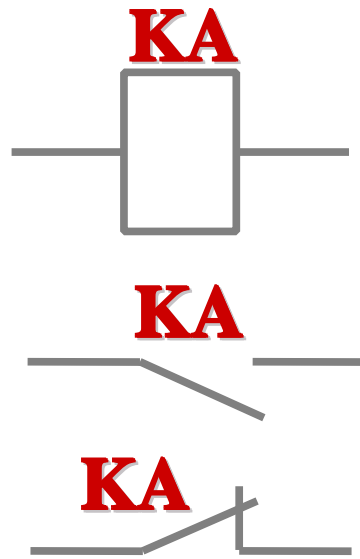

(b)



3

)

(

(a)

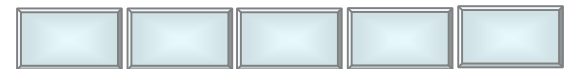
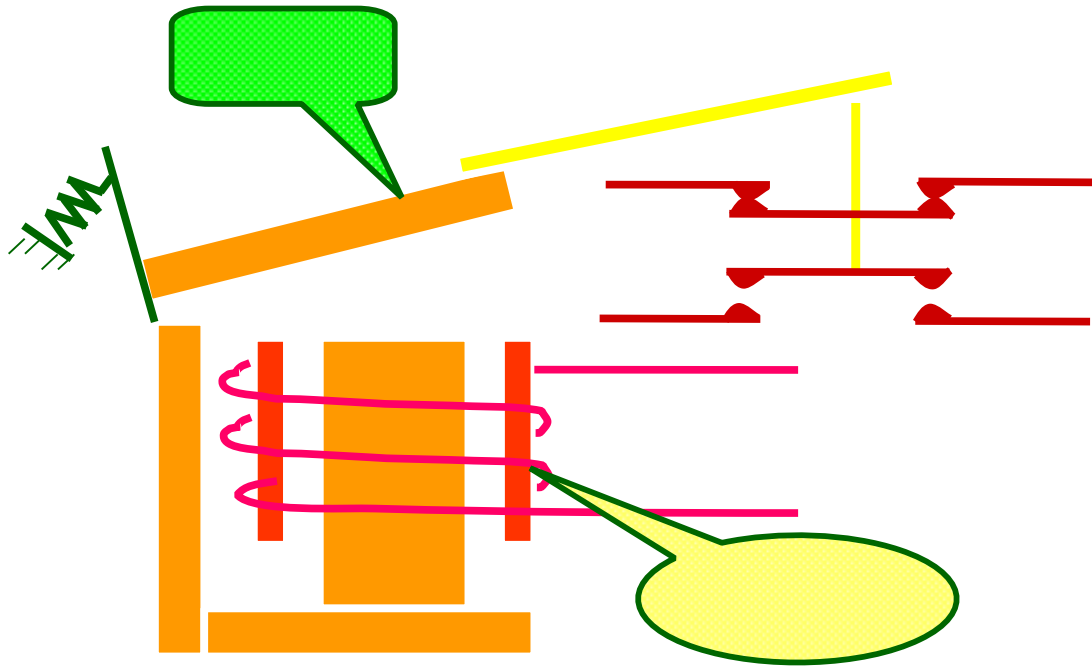

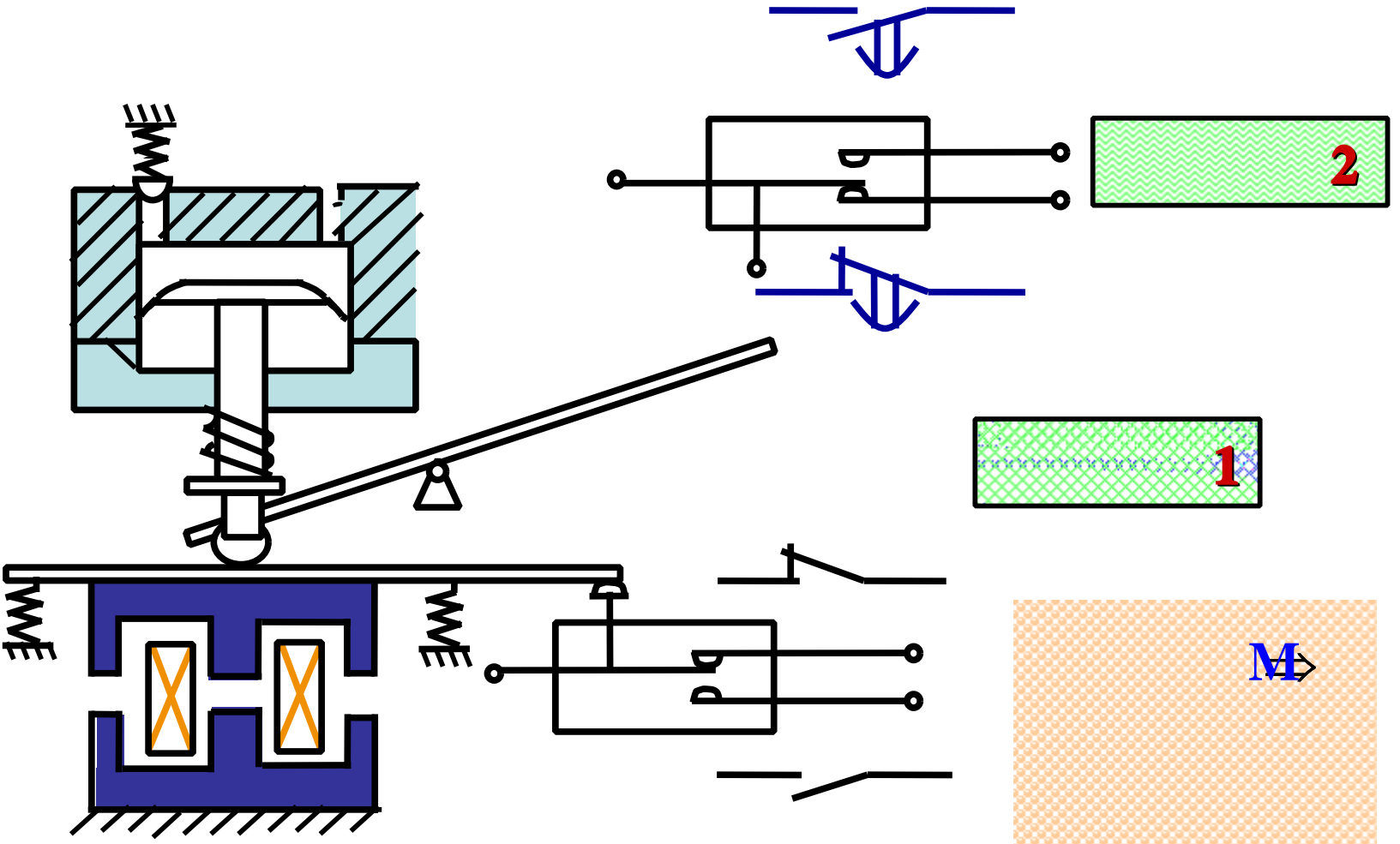

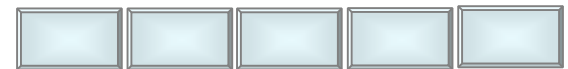
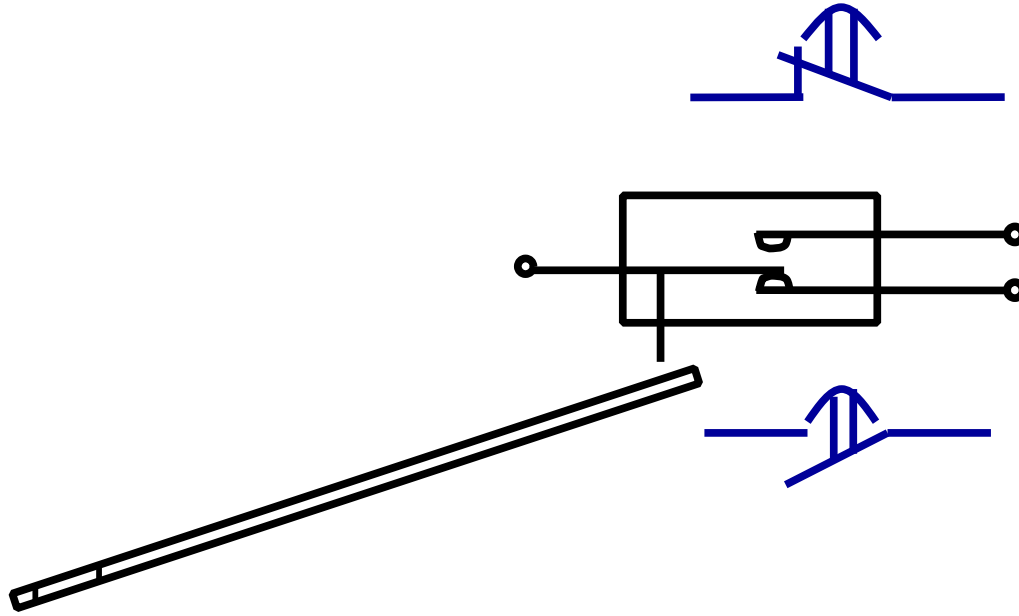
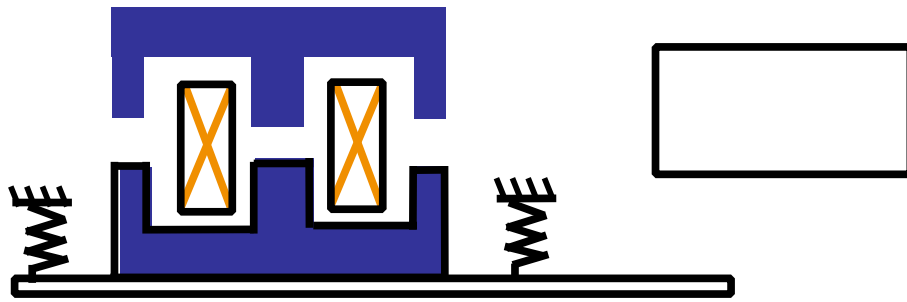

8.1.4

1.

2.

3.

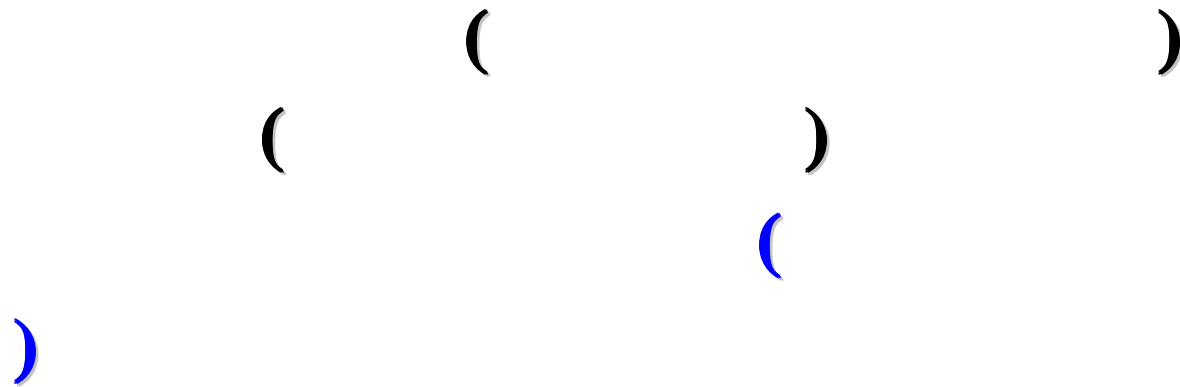

4.

5.

()

8.1.5

(2)

(3)



8.2

8.2.1

1.

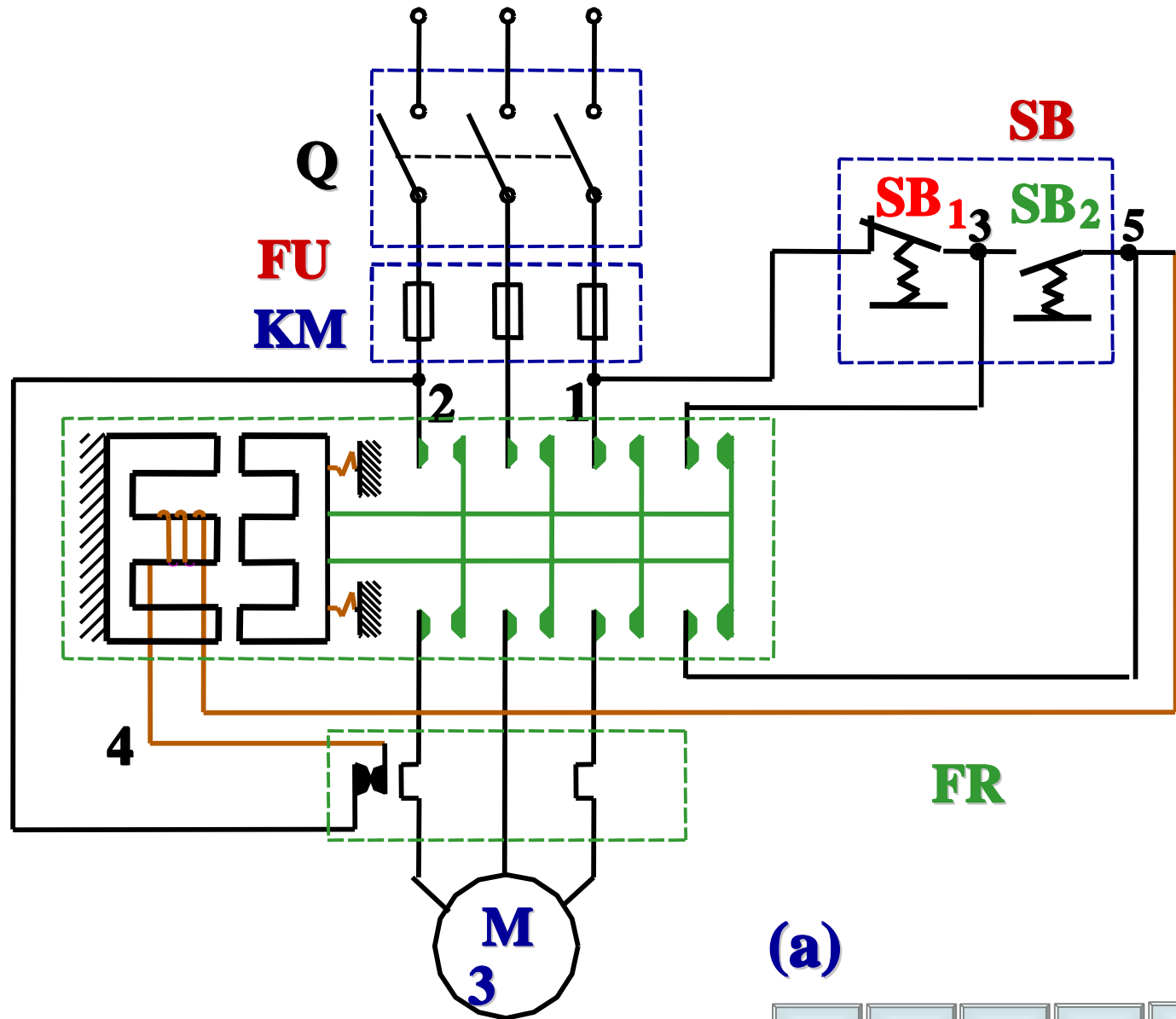

(a)



FU

()

()





2.

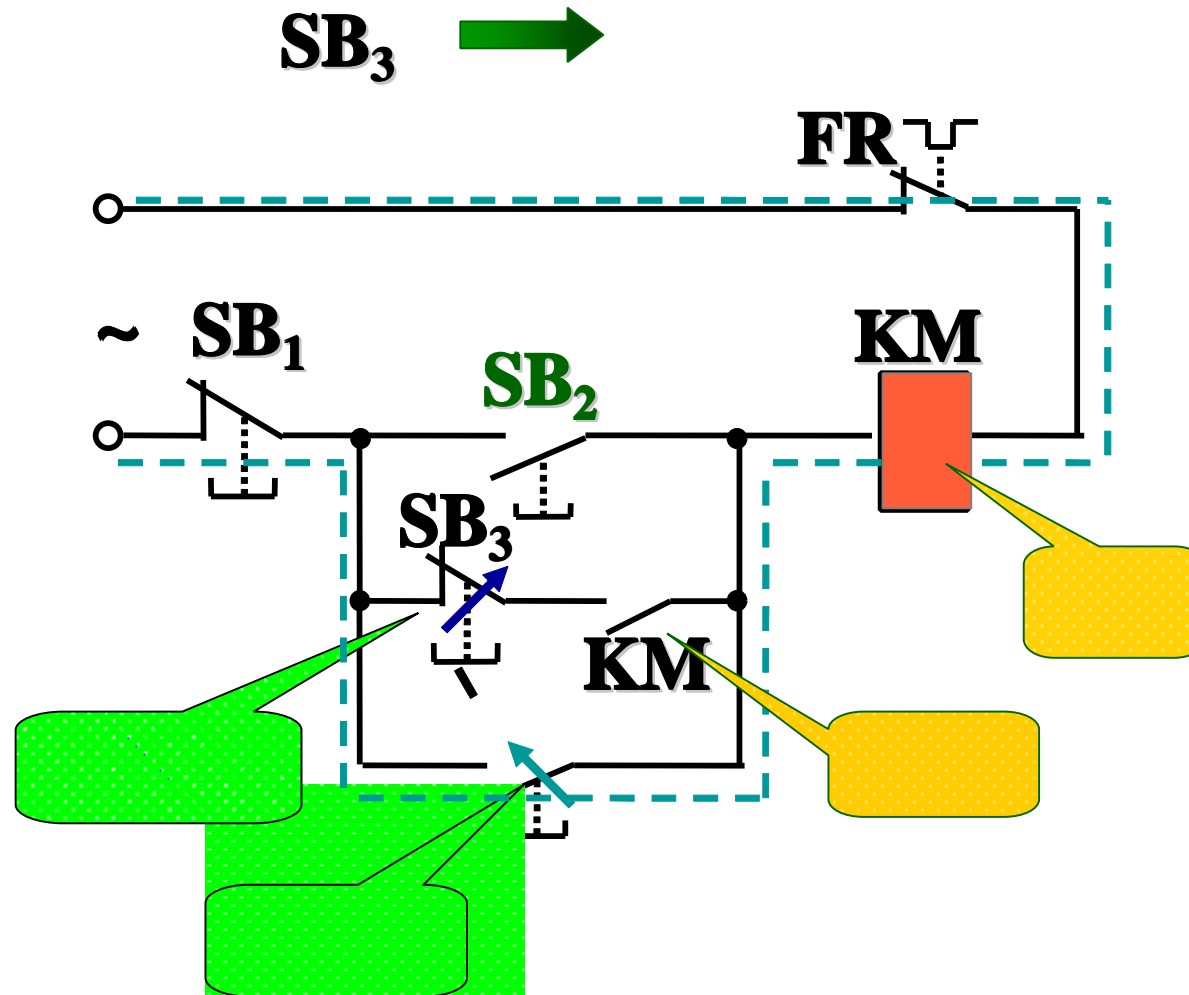

2.

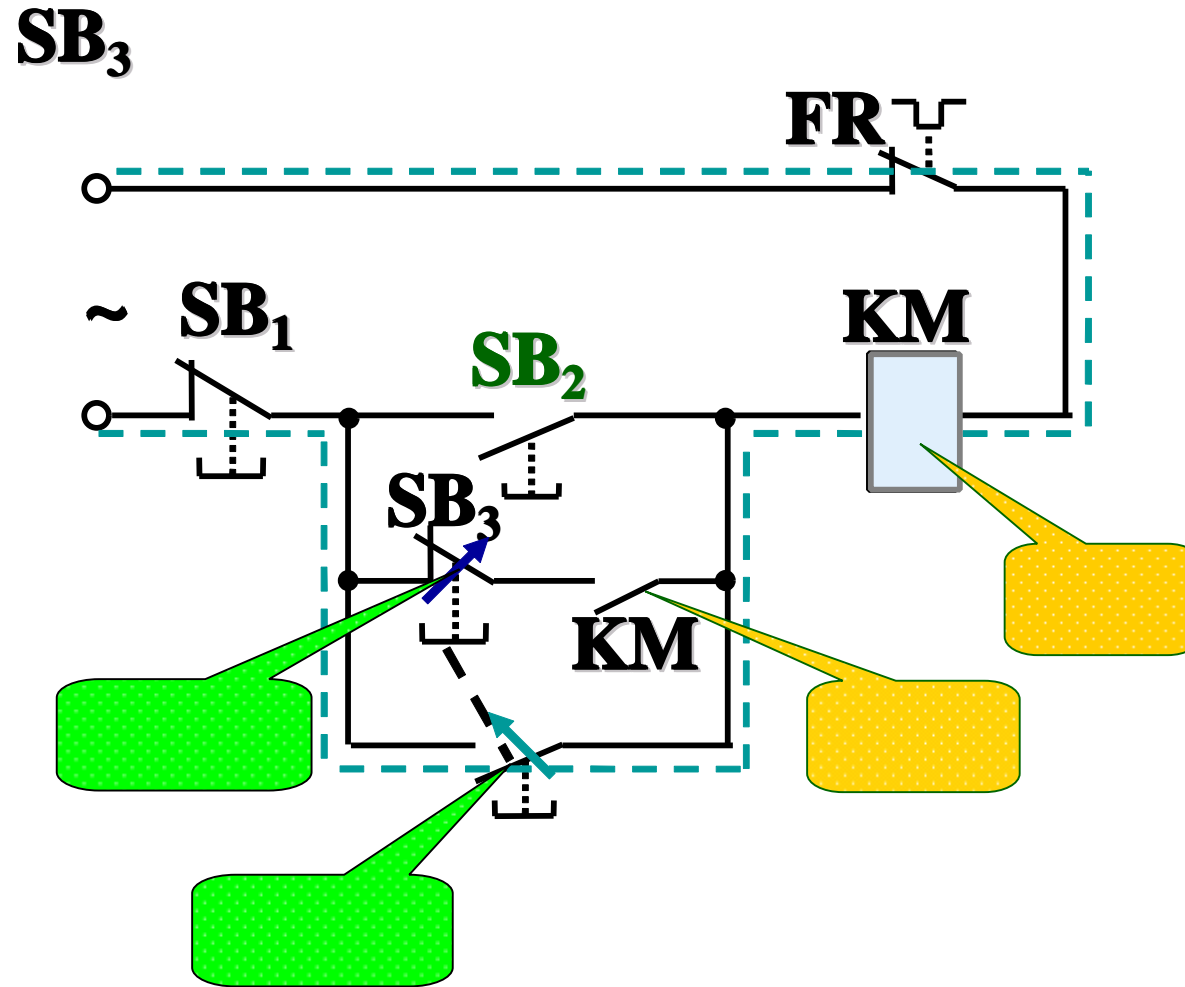

2.

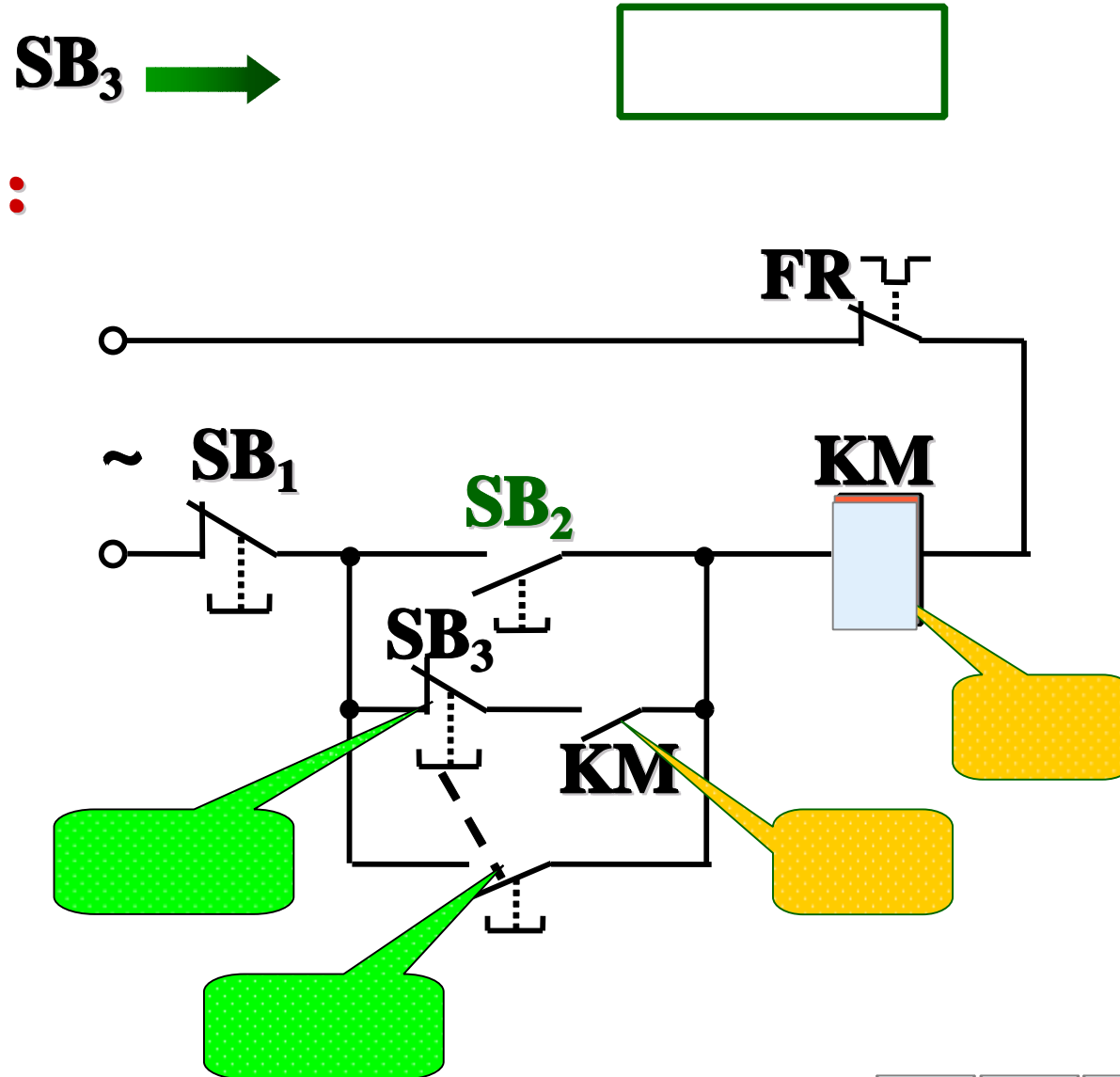

3.

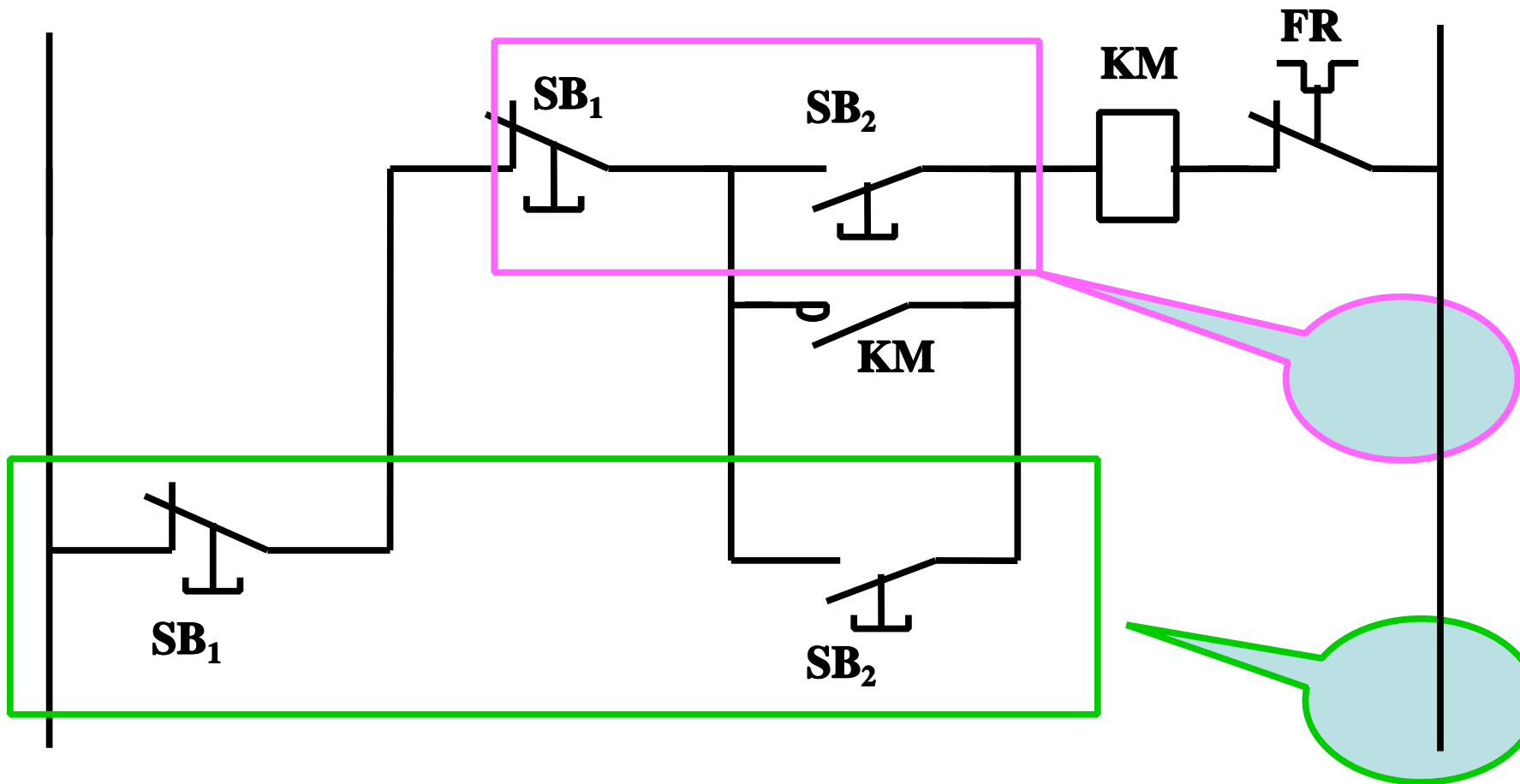

8.2.2

1.

2.

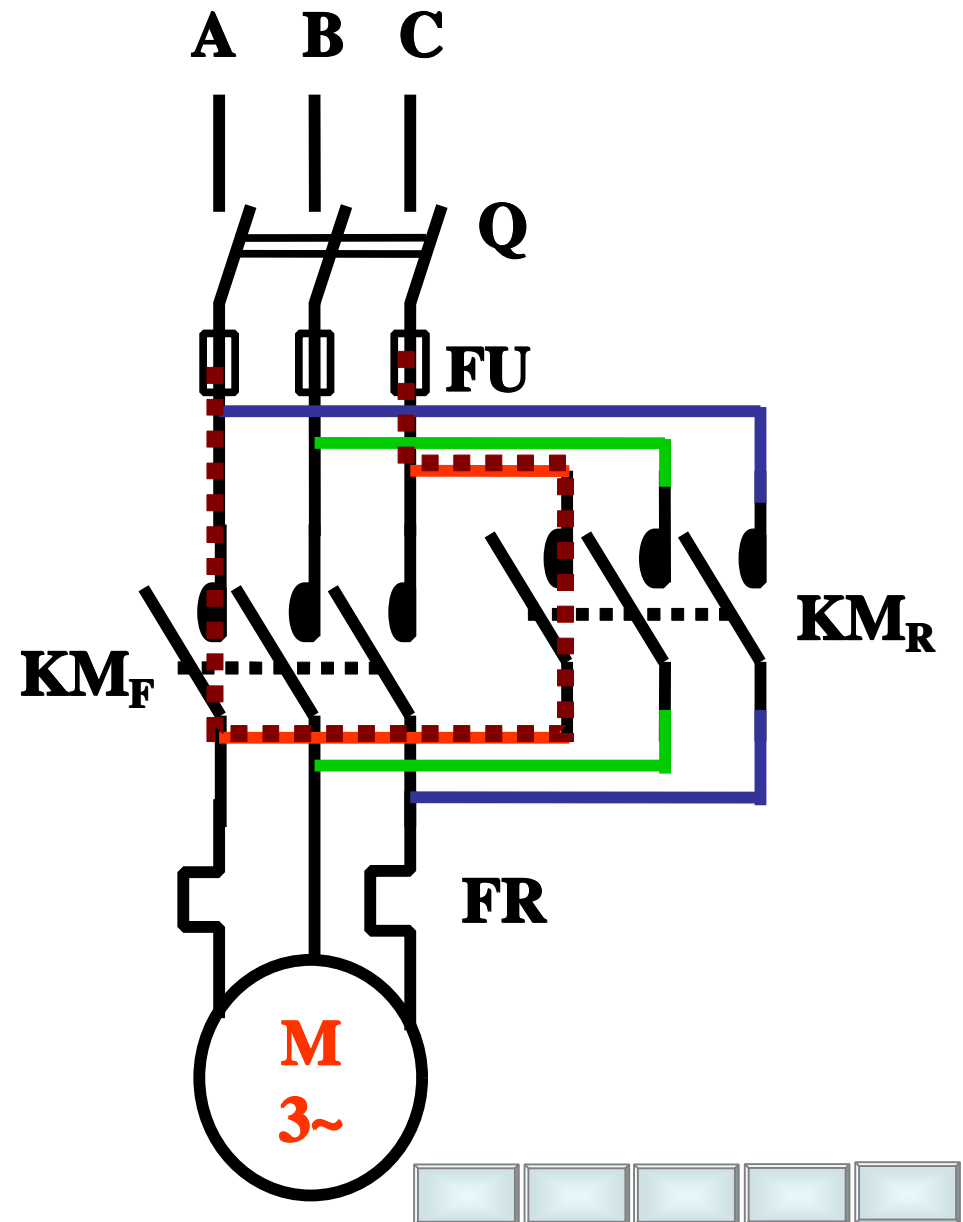

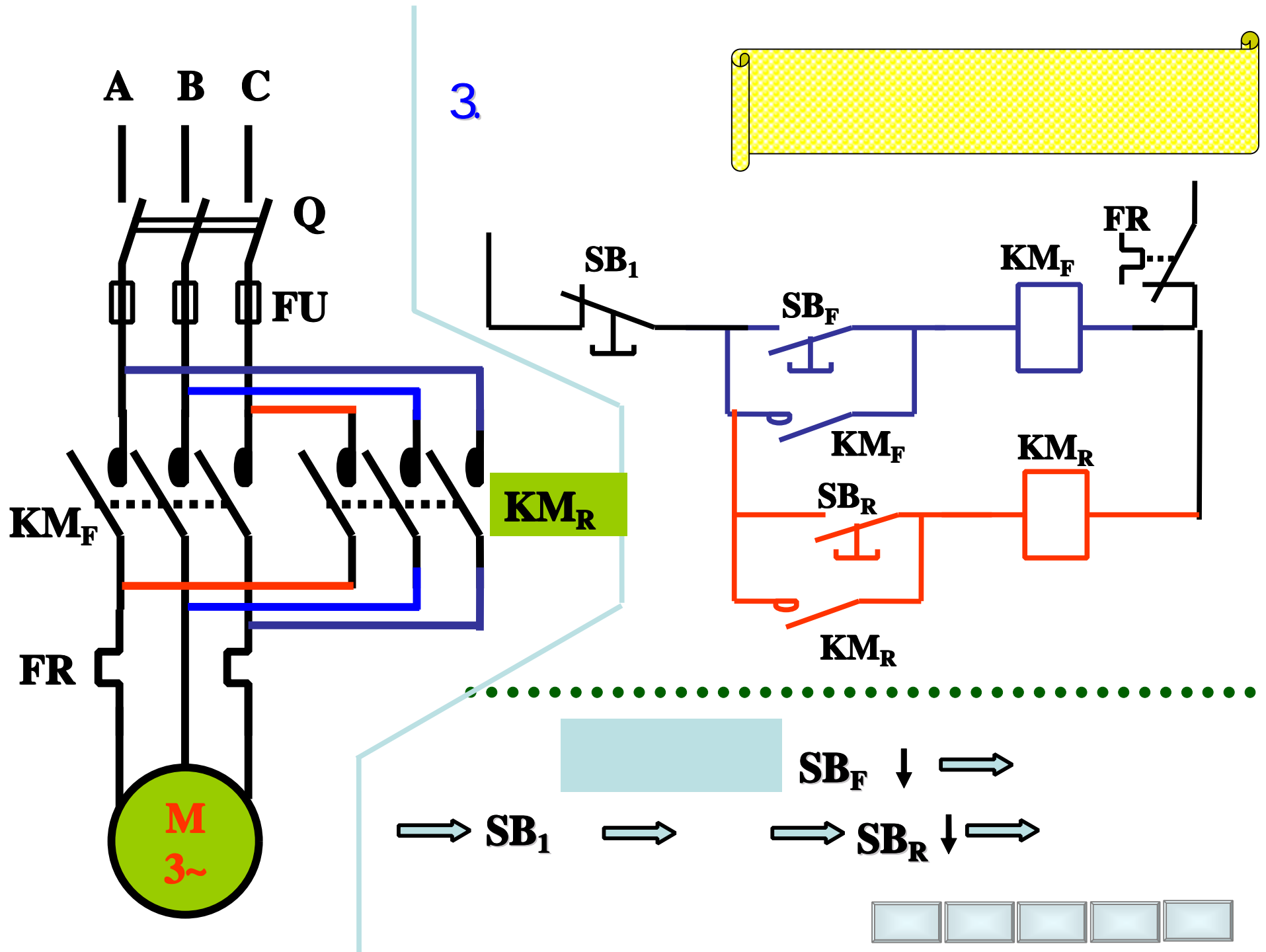

4.

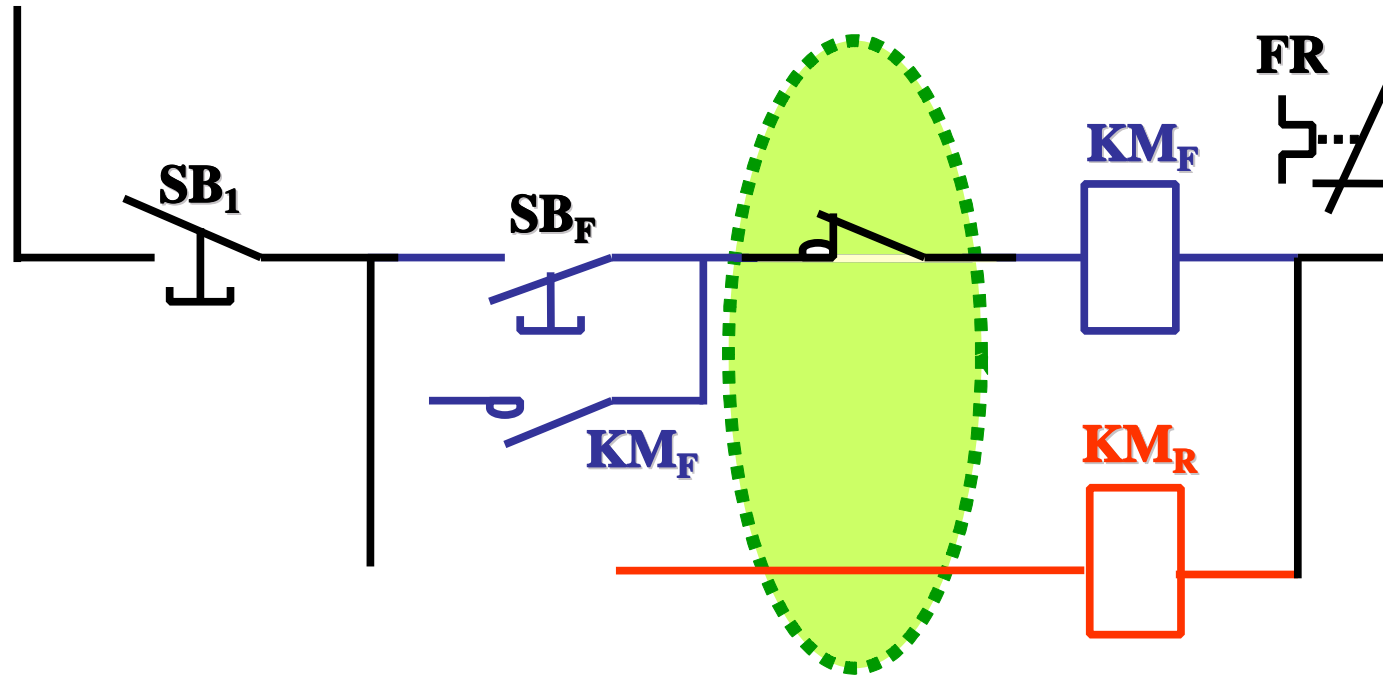

SB_R

SB_F



8.3

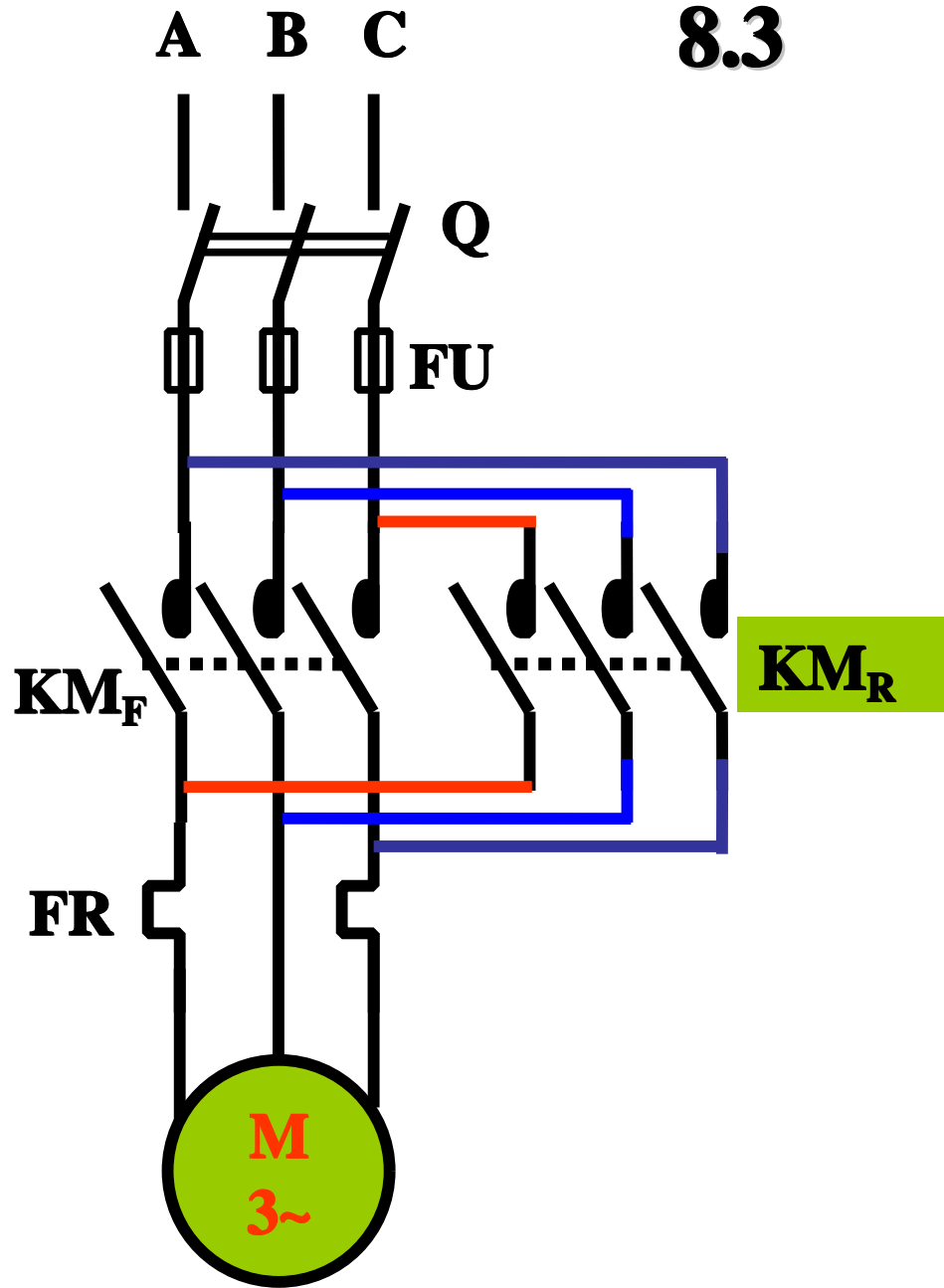

1.

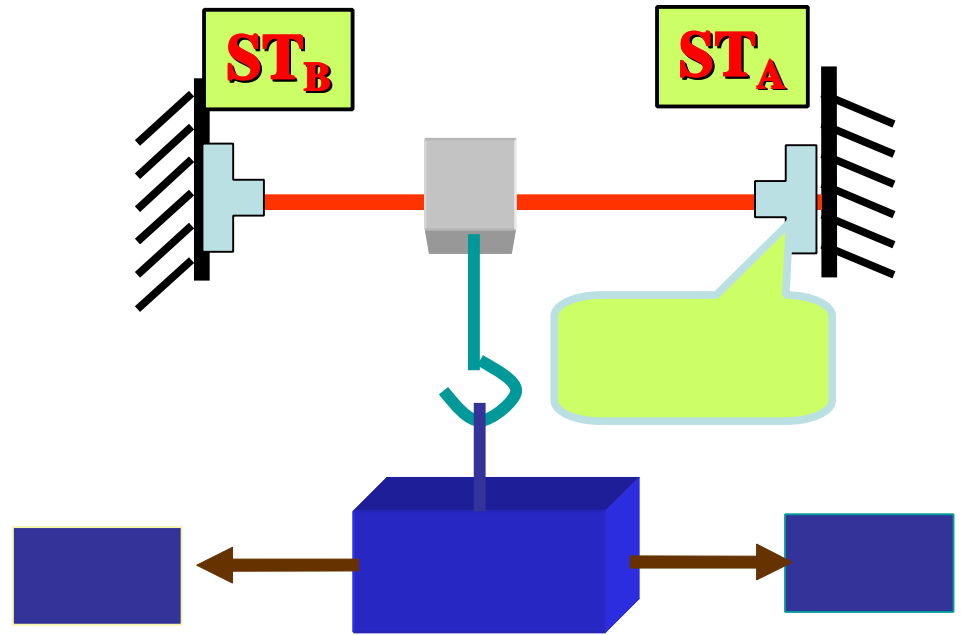
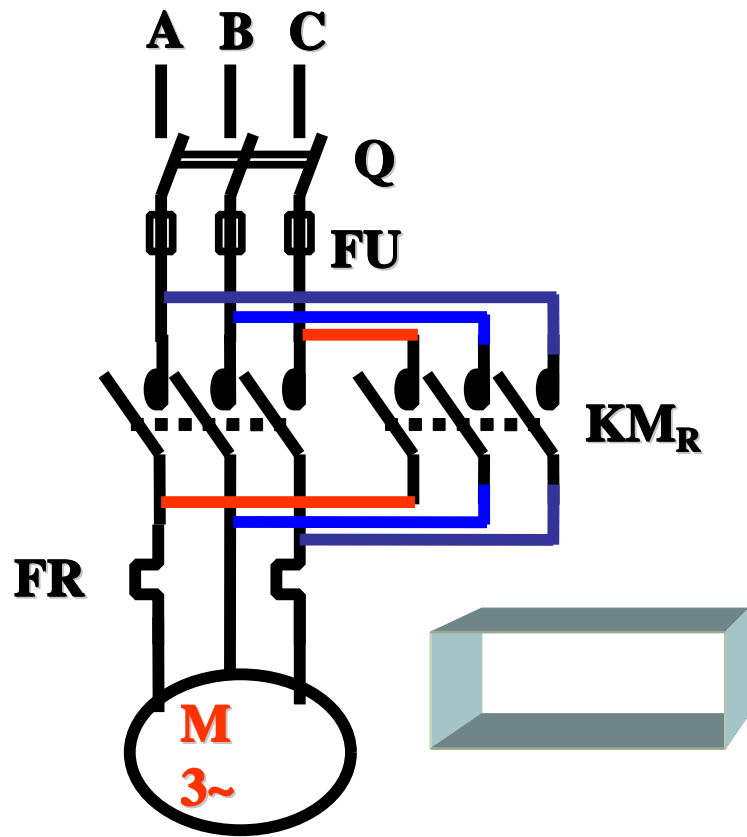
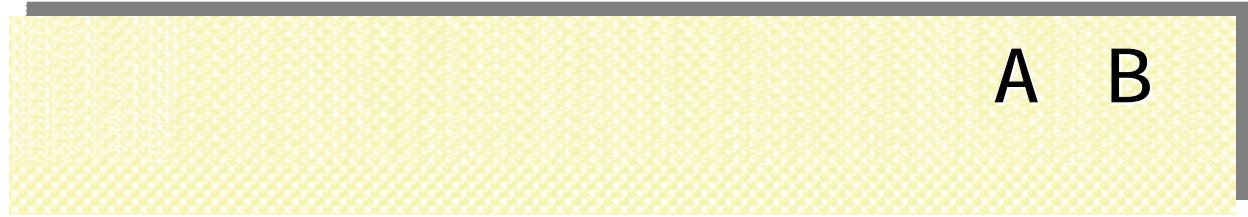

SB₂↓



ST_A

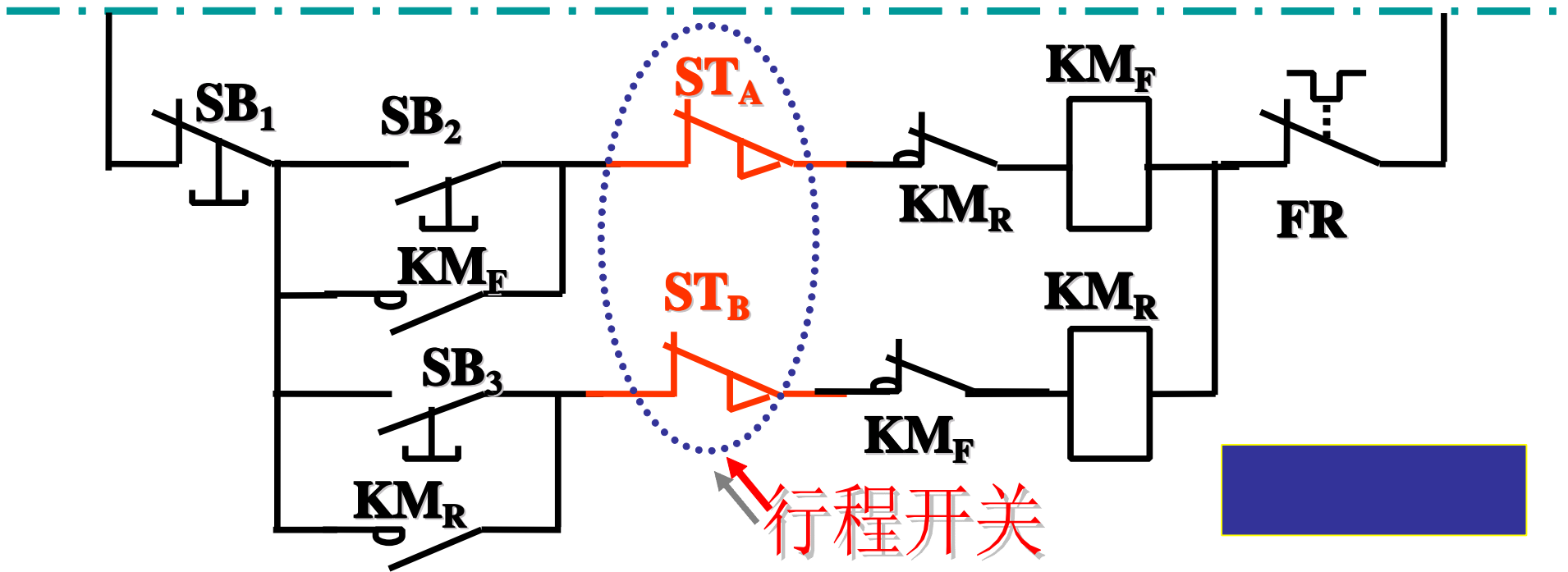

2.

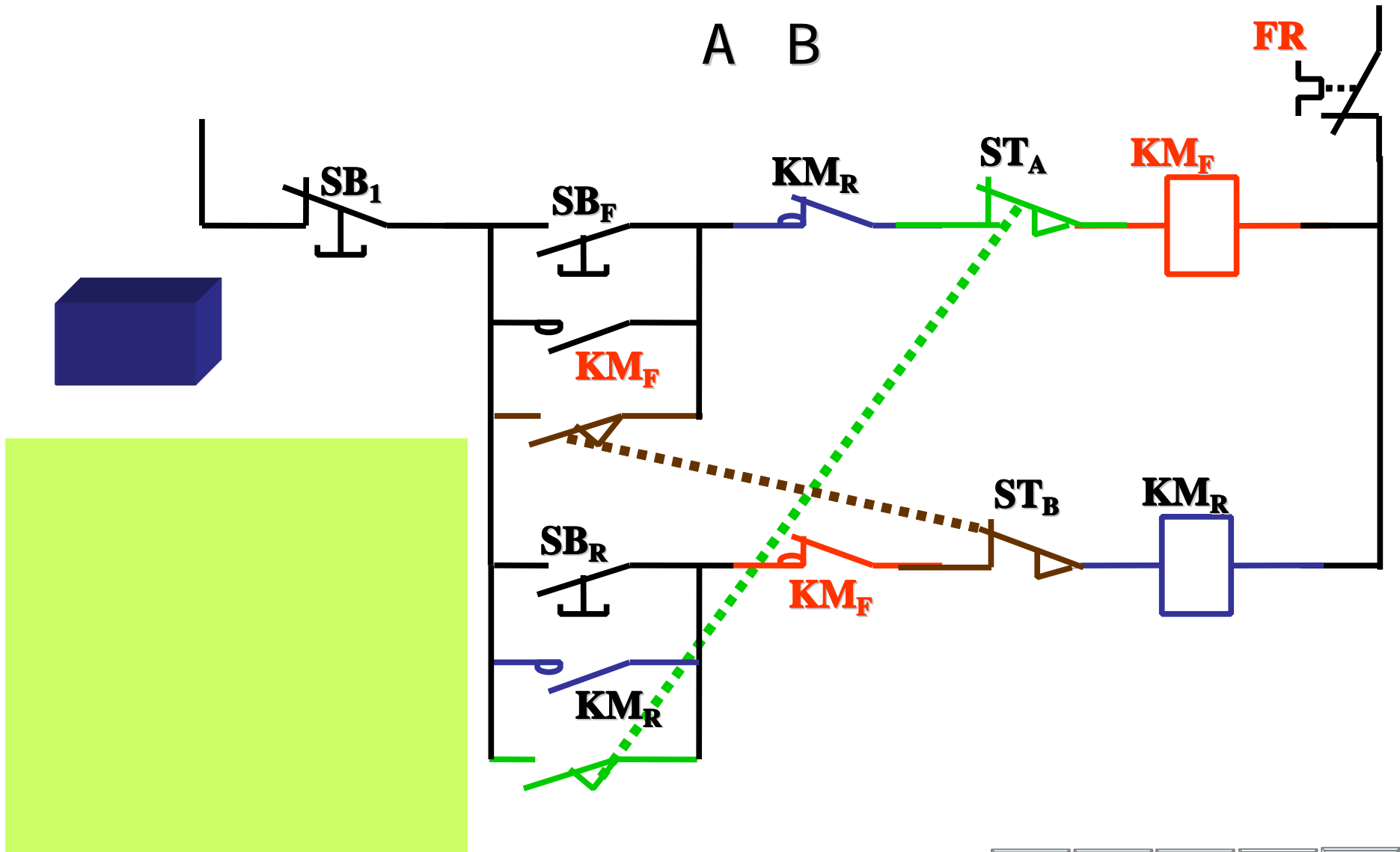

提示

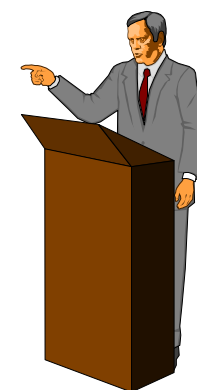
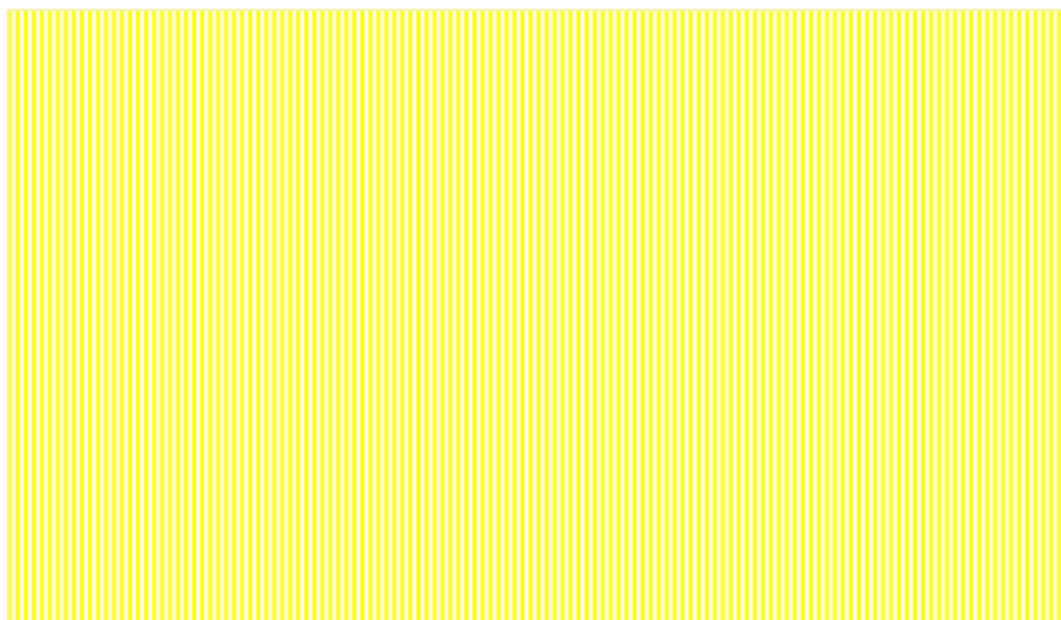

8.4

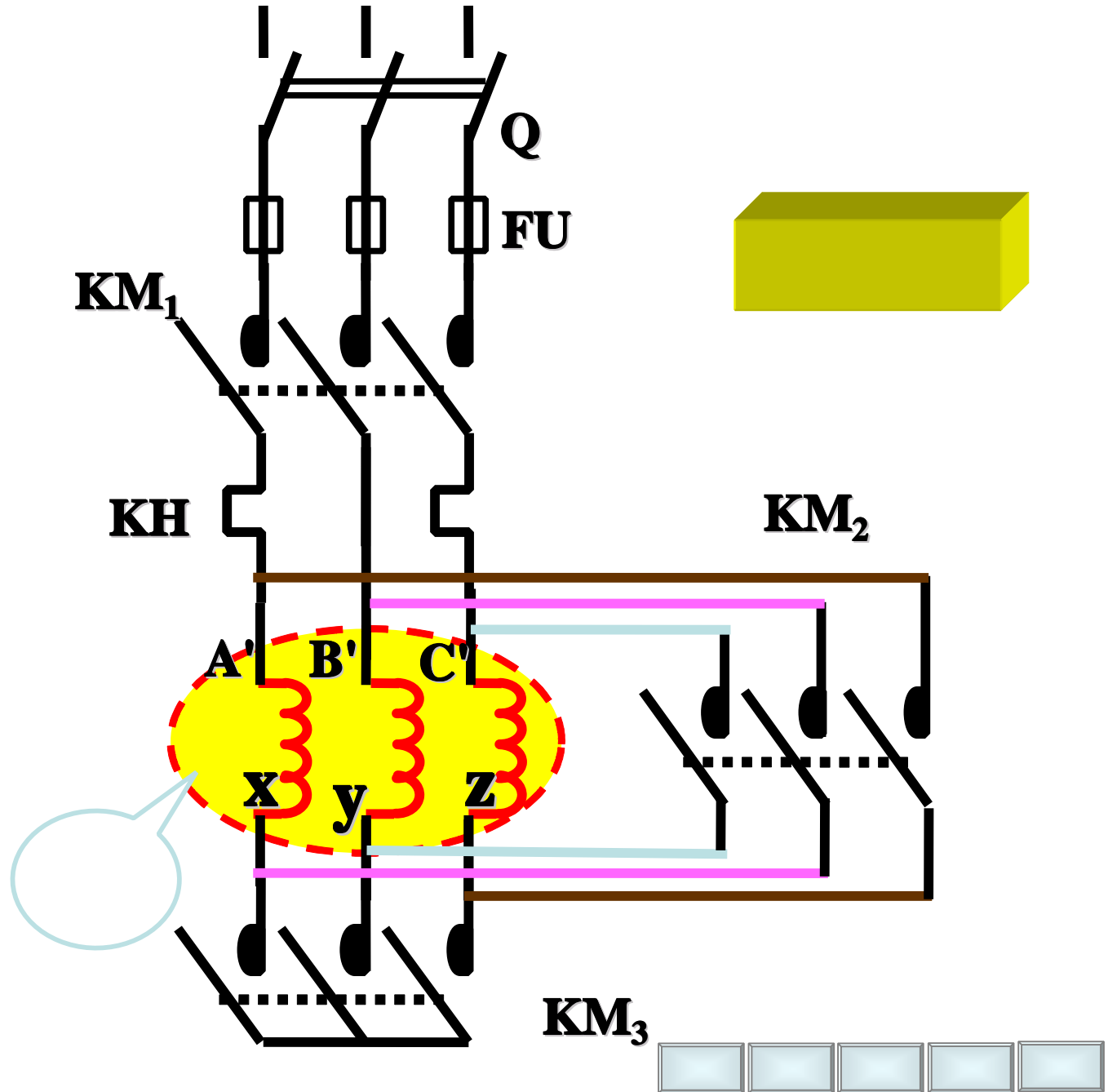
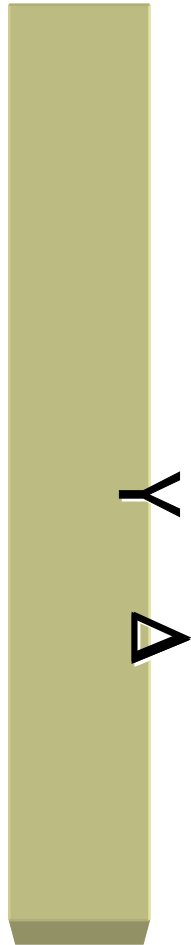

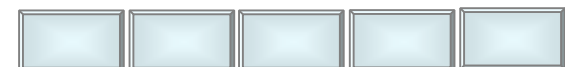
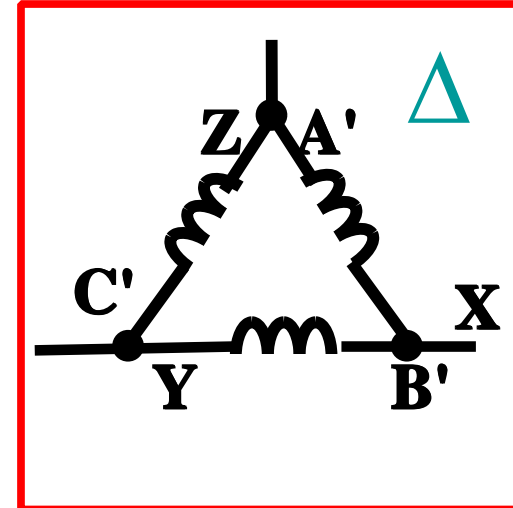
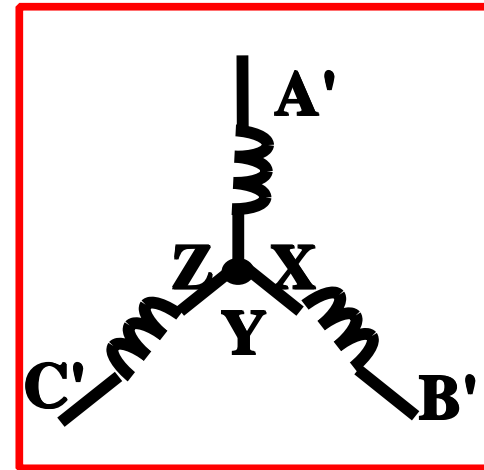
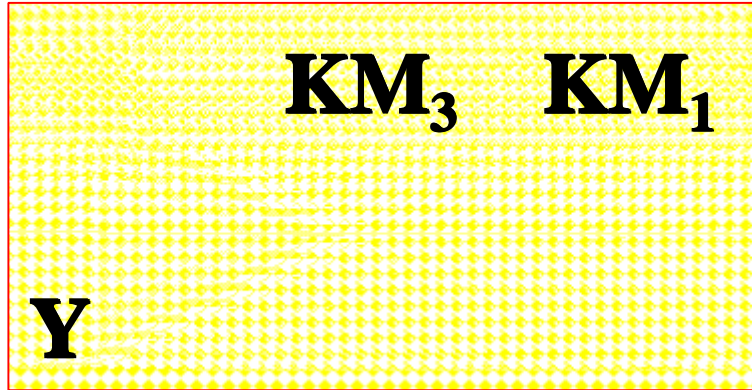

Y Δ

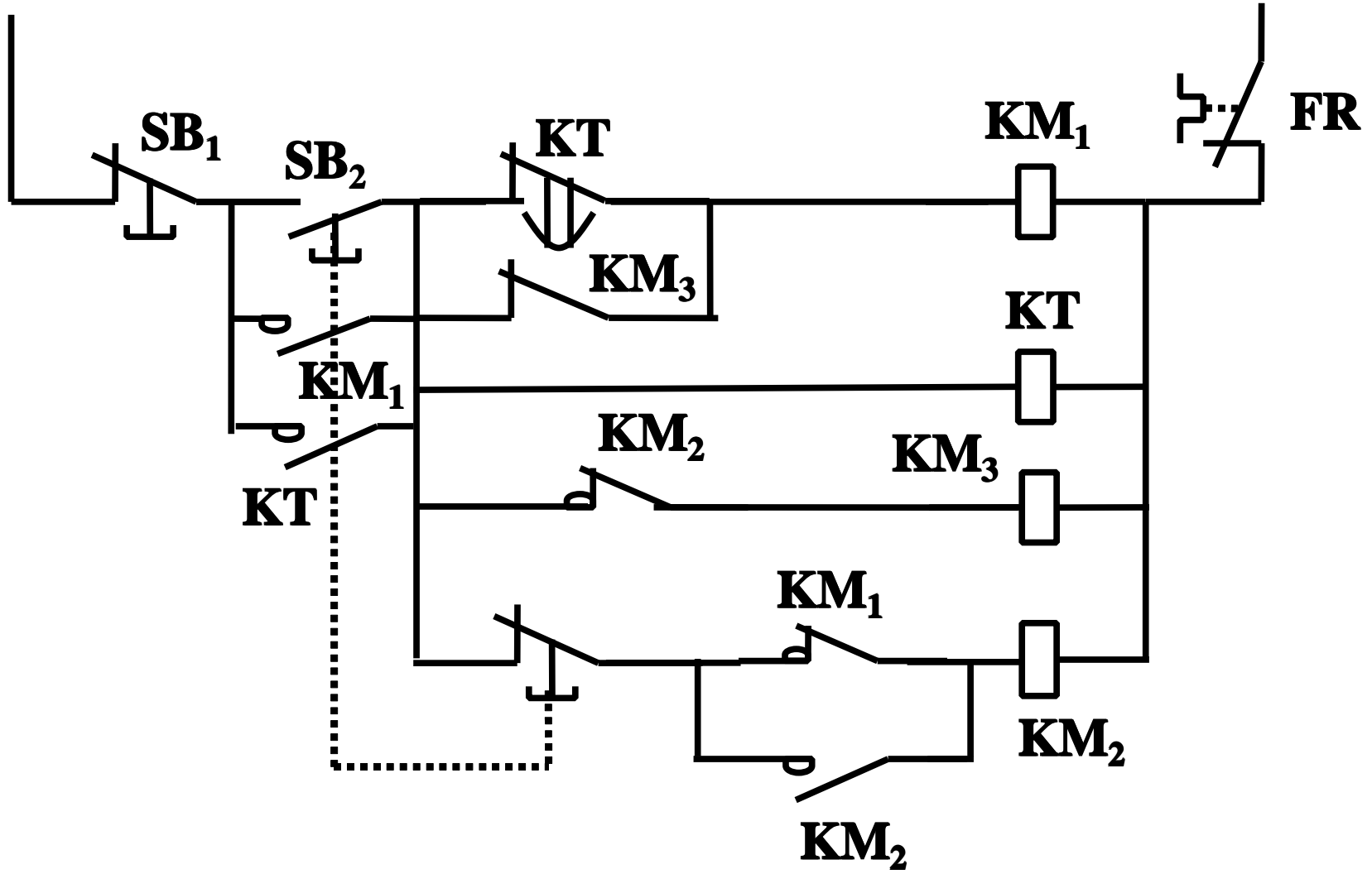

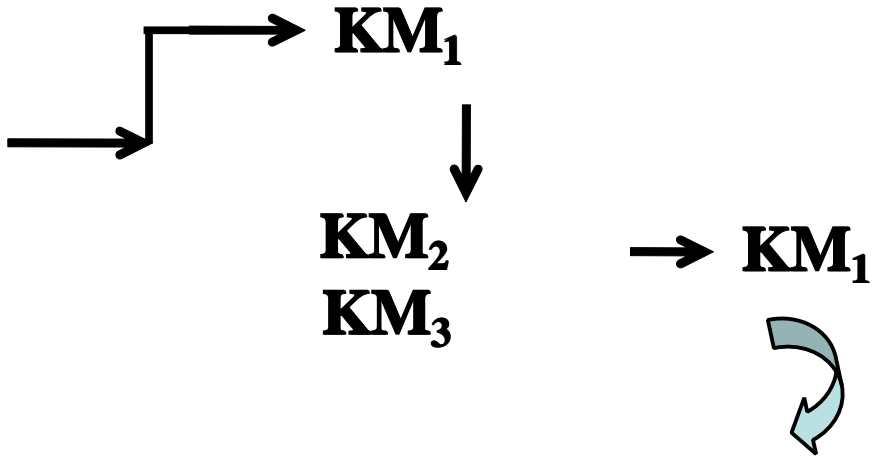
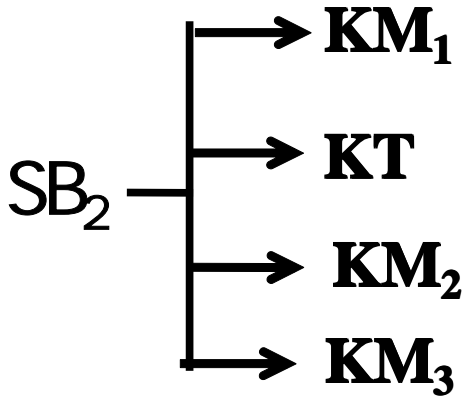
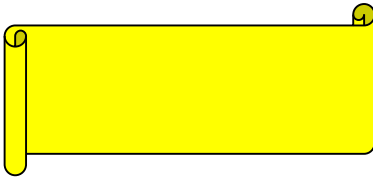

Y

Y ⇒ Δ

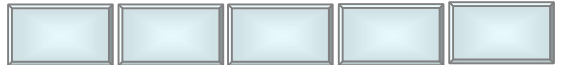

8.5

1. M_2

M_1

M_2

$SB_1 \rightarrow M_1$

$SB_2 \rightarrow M_2$

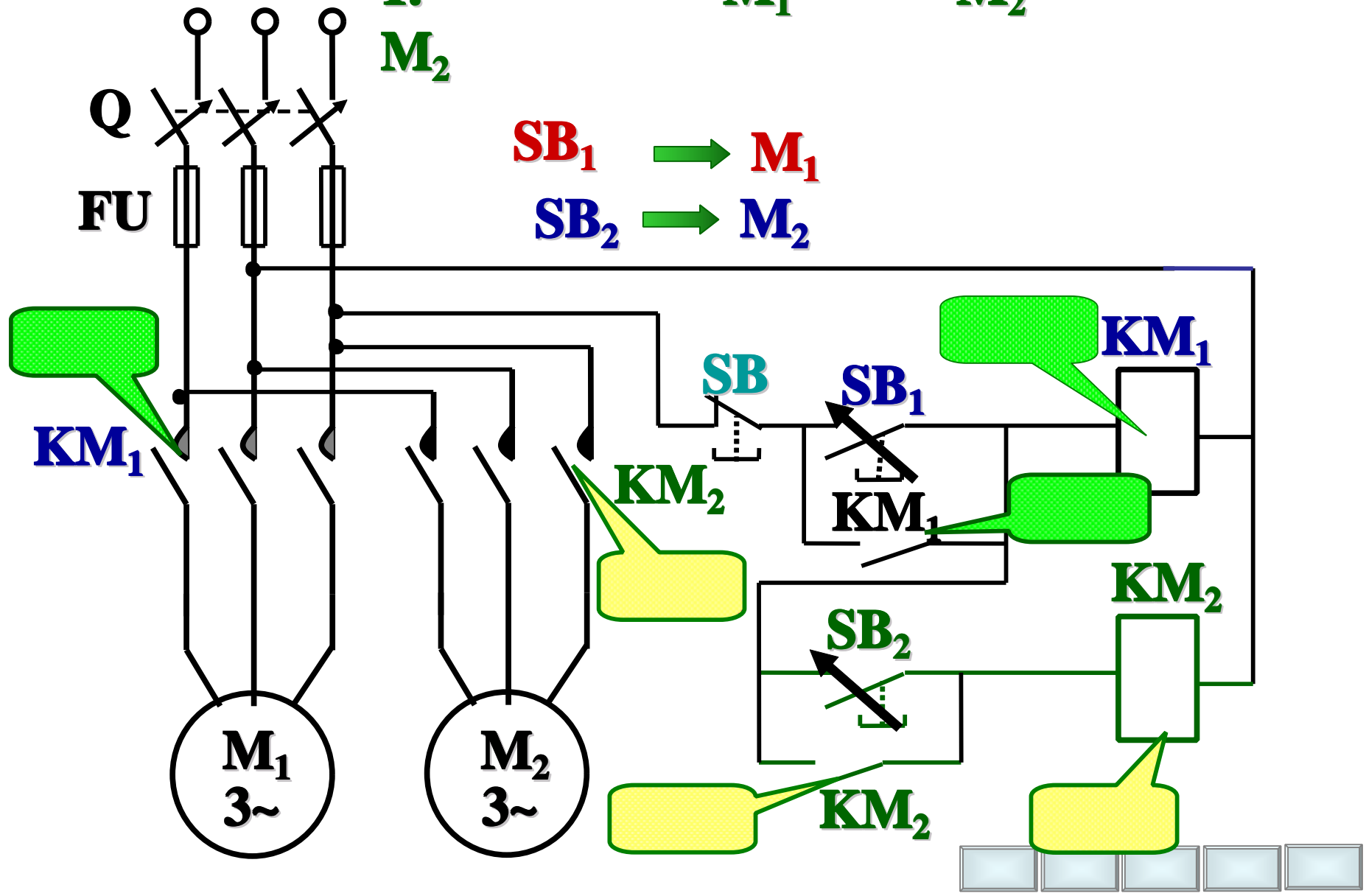

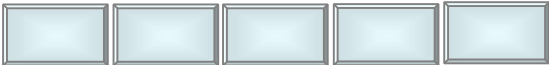
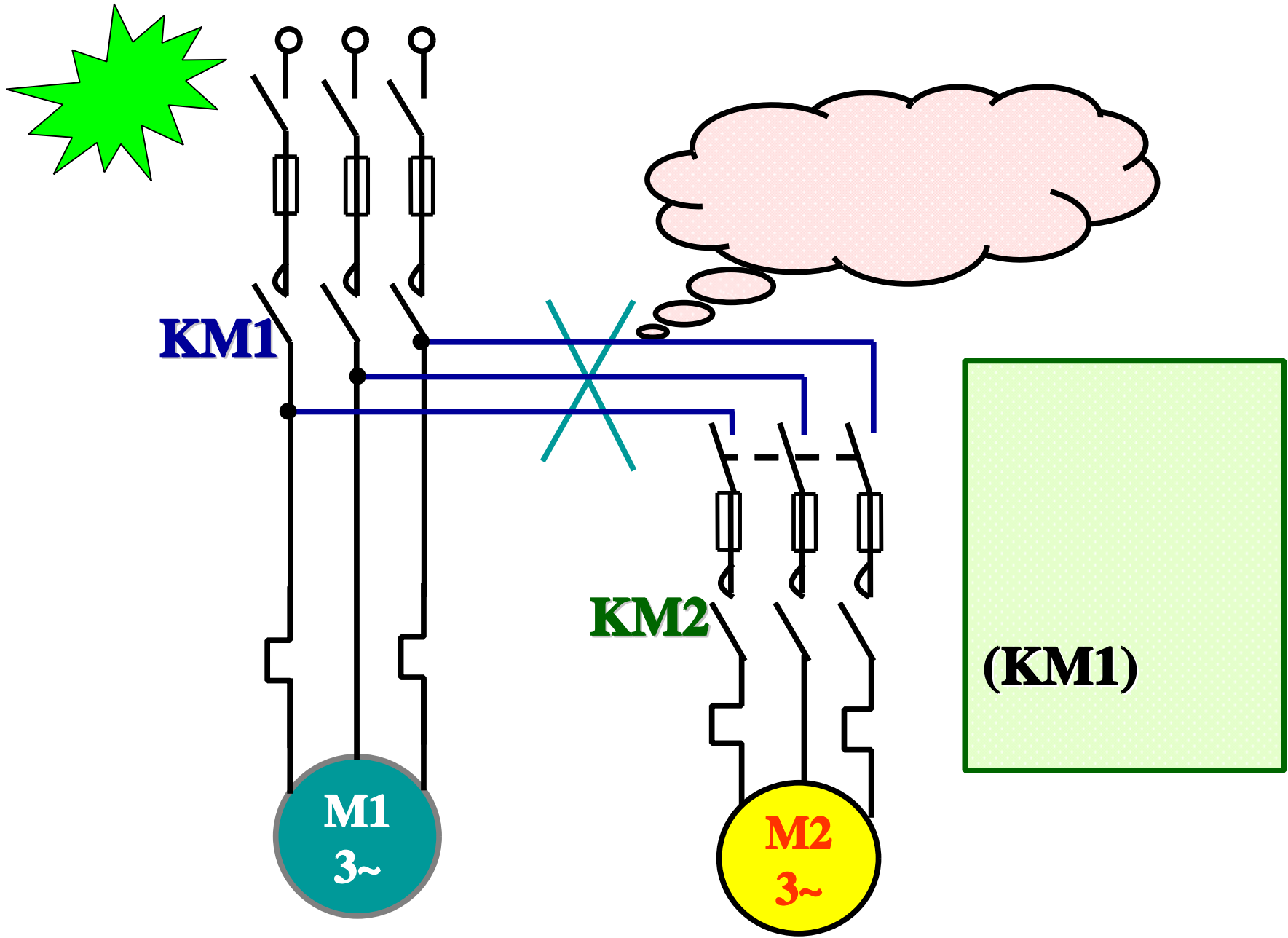

1

: M₁
: M₂

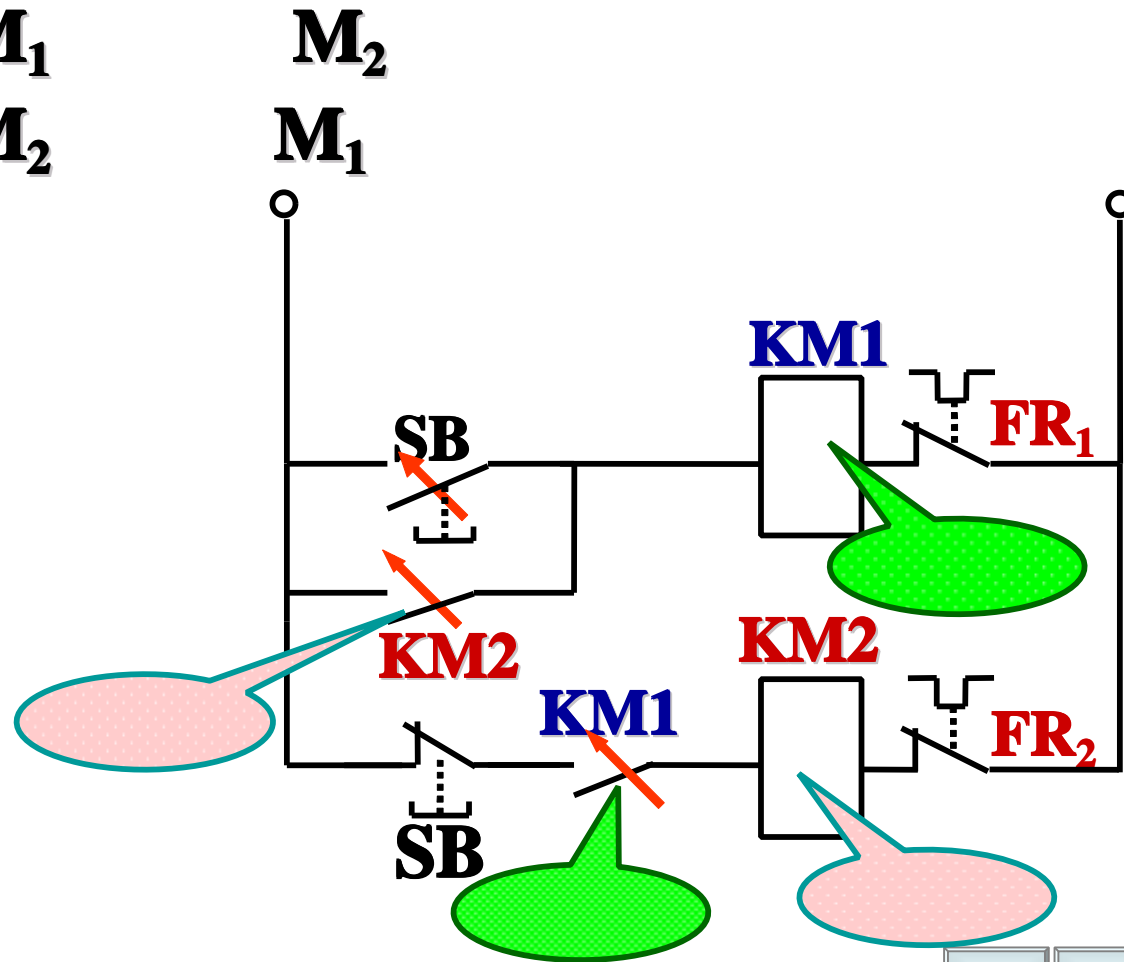

2.

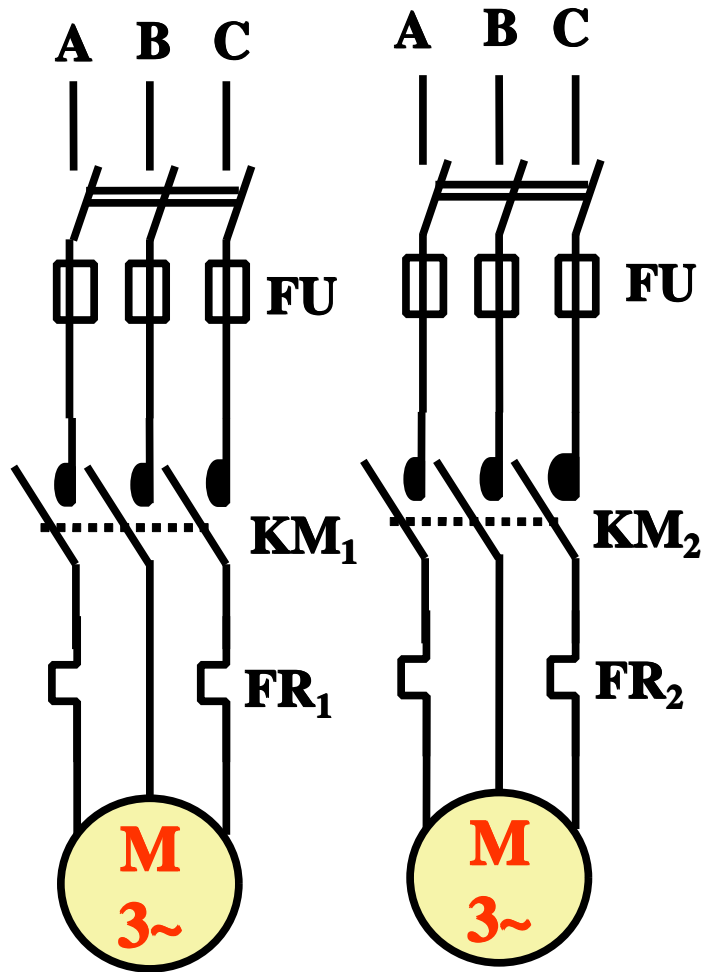

M1
M2

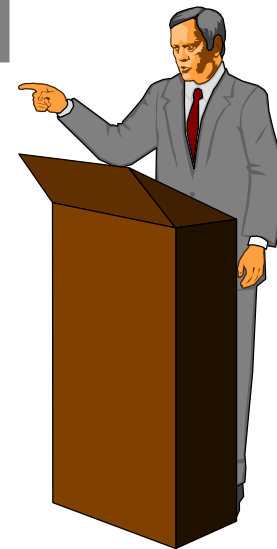

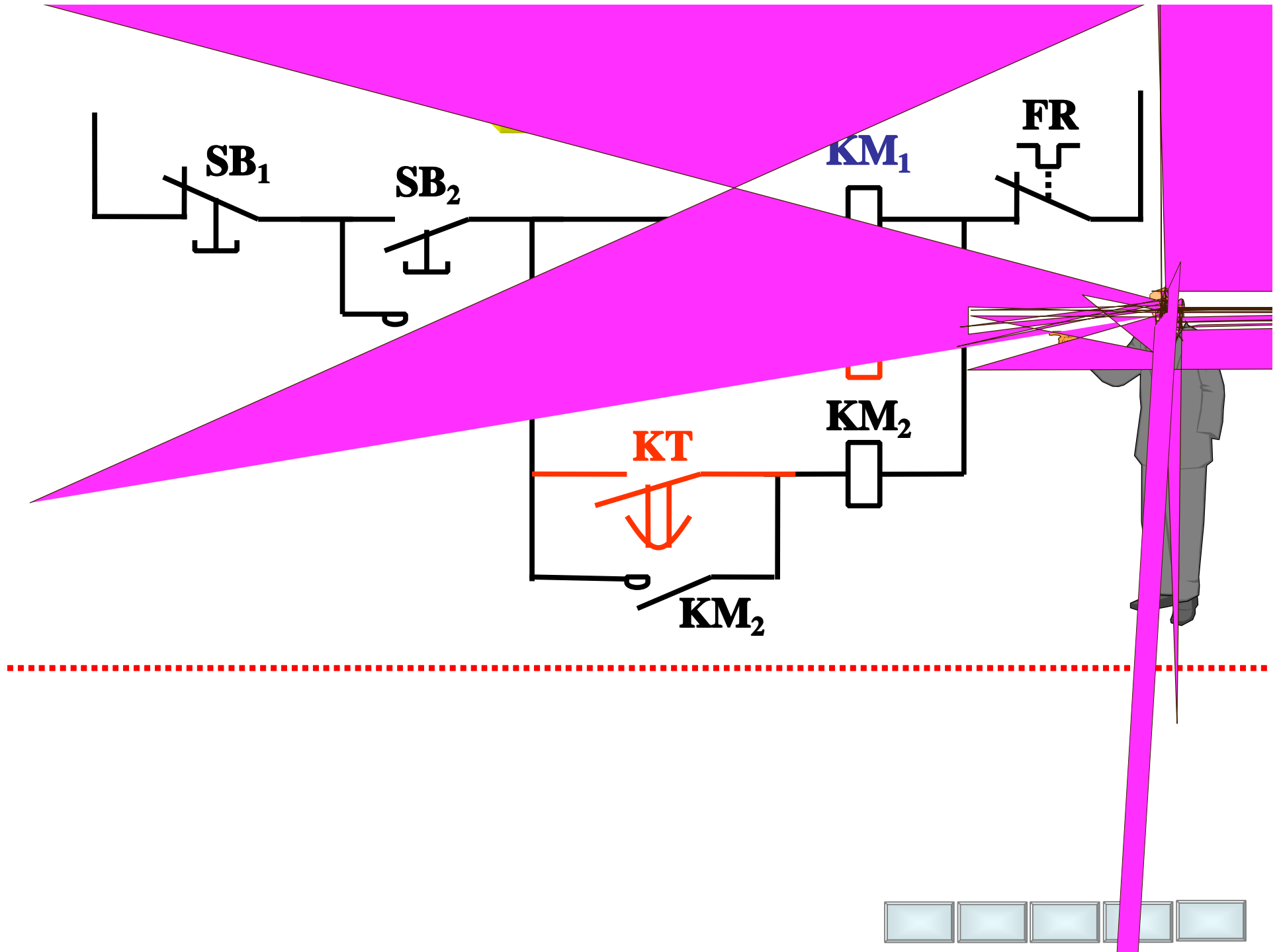

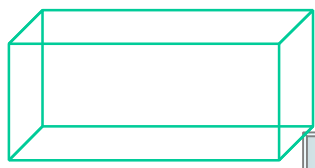
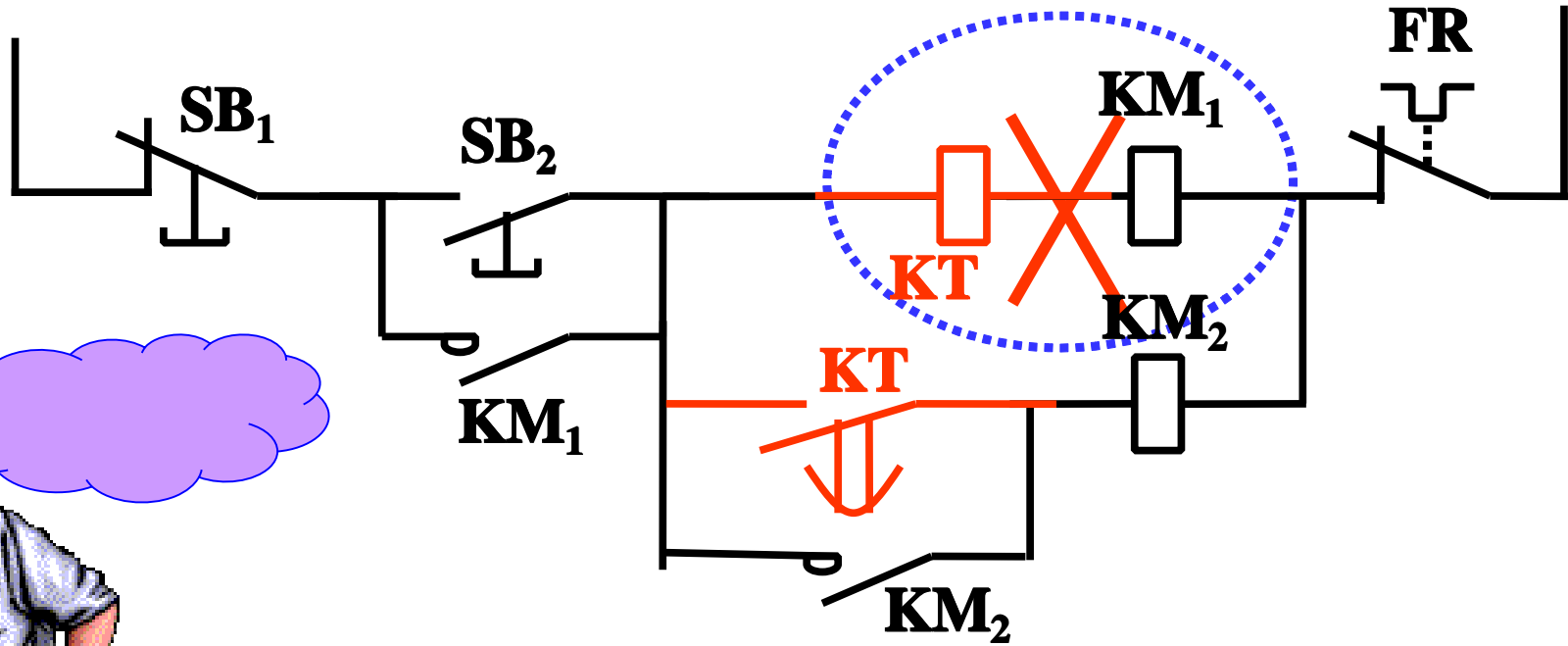
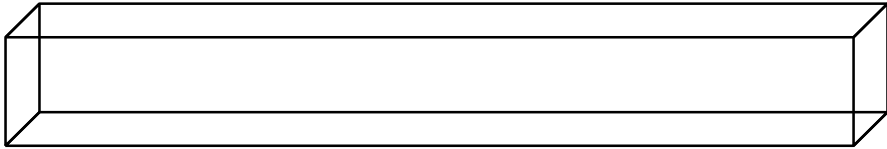

1.

A
B

1
1

A

B
A

2.

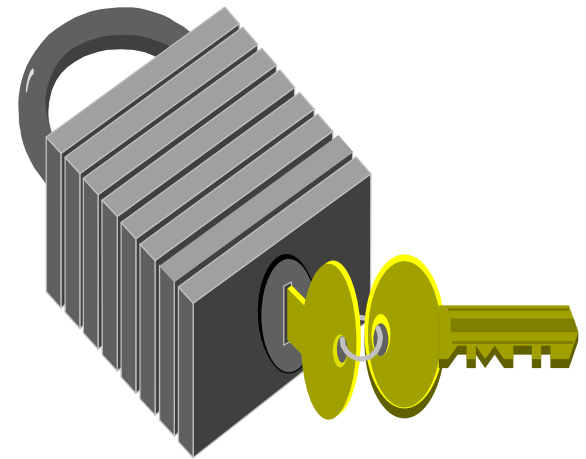

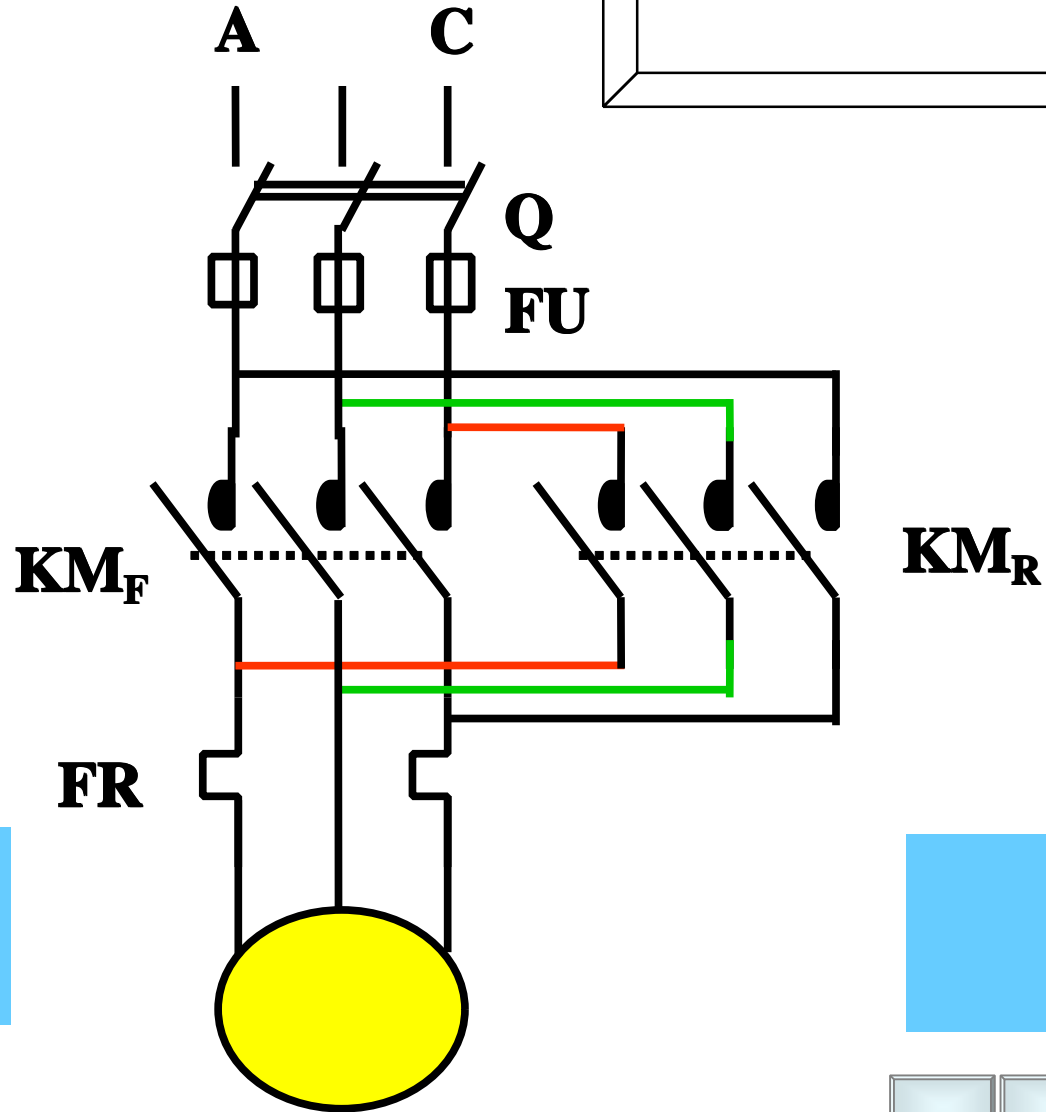

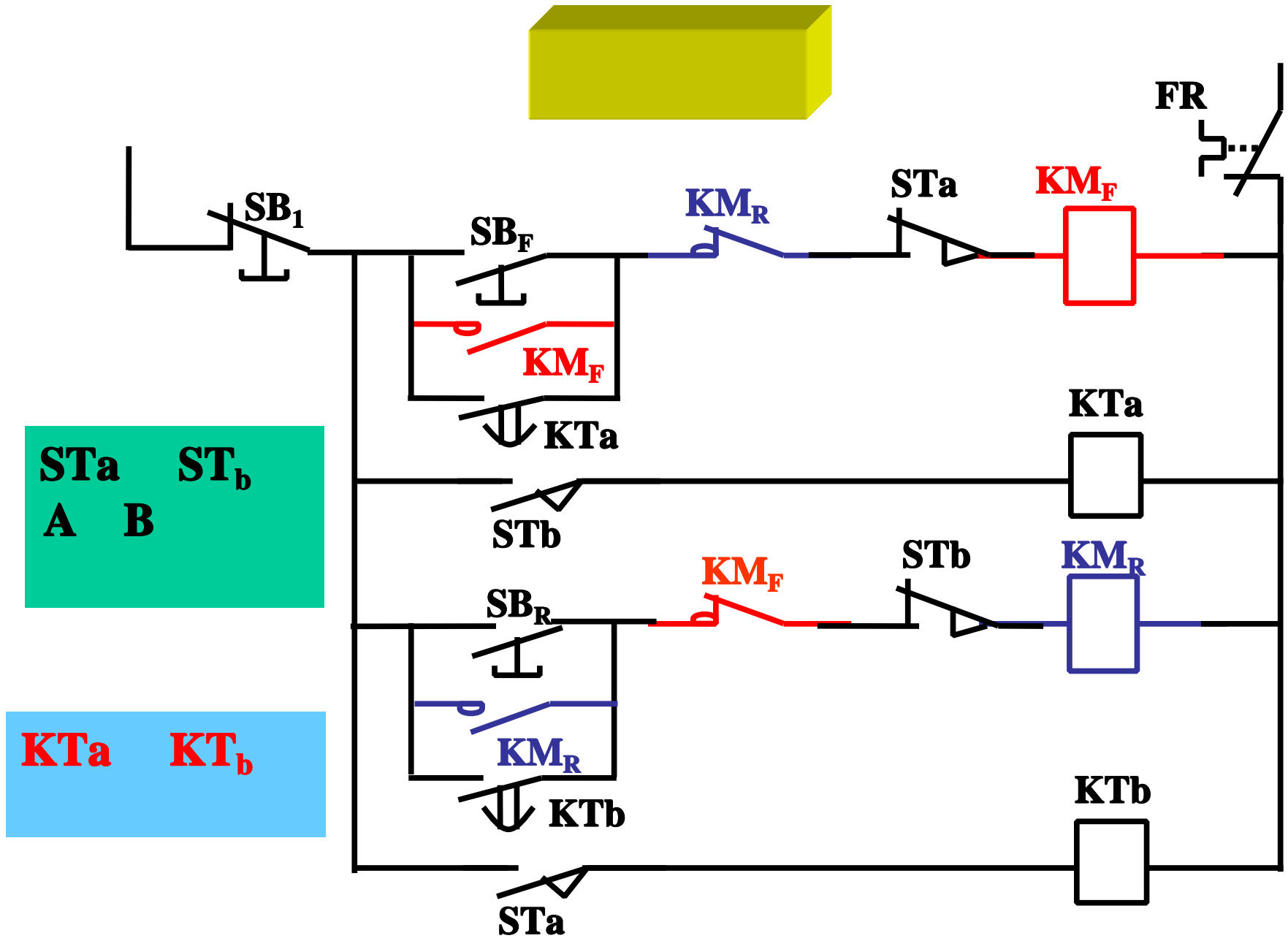

ST_a ST_b
A B

KT_a KT_b

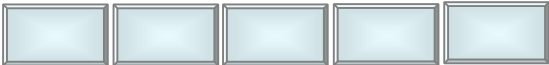

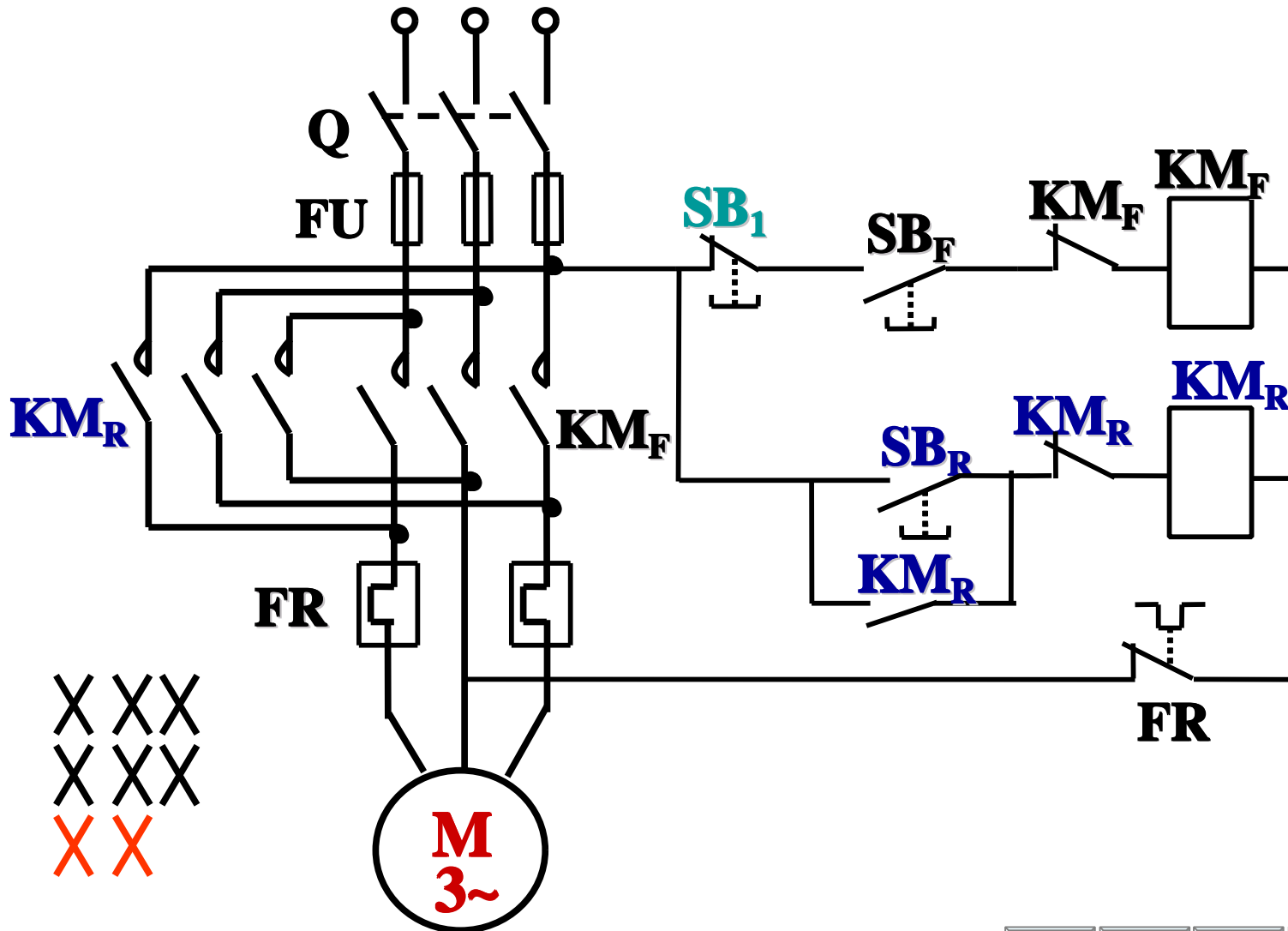

XXX
 XXX
 XX



