

$$y(t) = x(t) * h(t) = \int_{-\infty}^{\infty} x(\tau) h(t - \tau) d\tau$$

$$f_1(t) \quad f_2(t)$$

$$f(t) = \int_{-\infty}^{\infty} f_1(\tau) f_2(t - \tau) d\tau \quad f_1(t) \quad f_2(t) \quad f_2(t) \quad f_1(t)$$

$$x(t) \quad h(t)$$

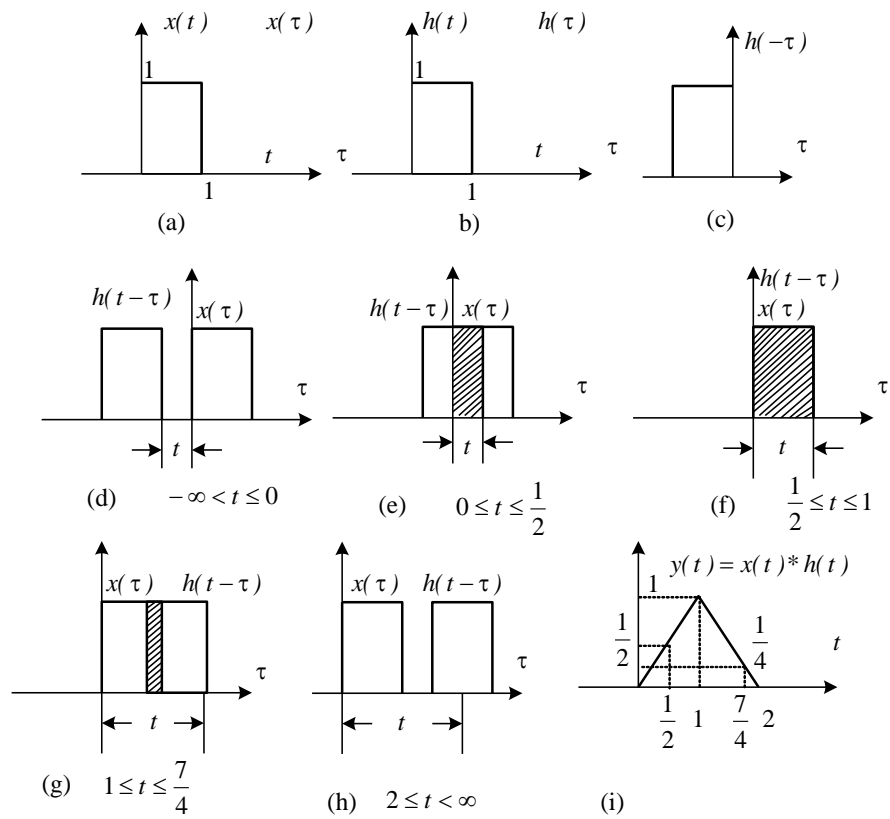

$$f_1(t) \quad f_2(t) \quad f_1(t)$$

$$f_2(t) \quad f(t)$$

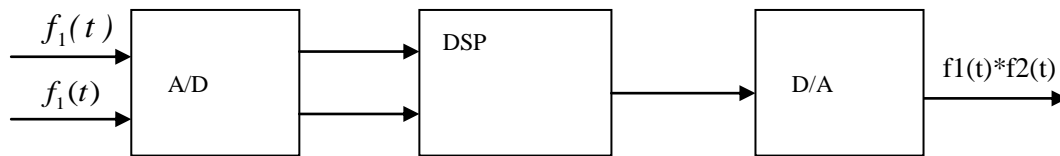
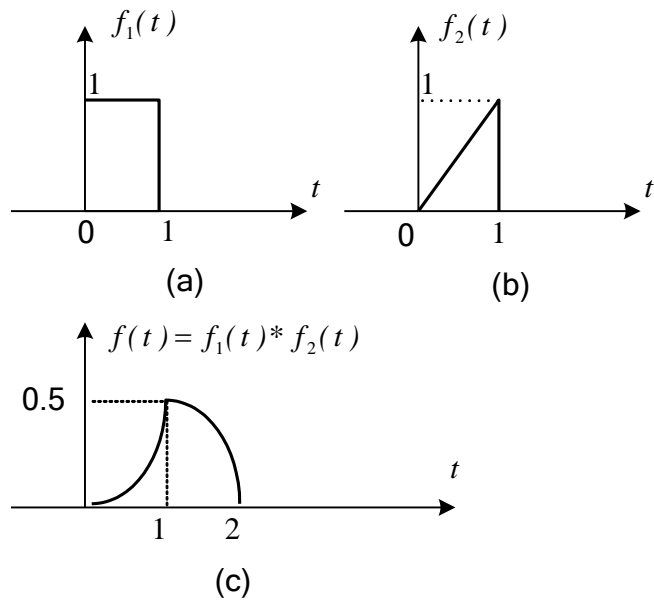

$f_1(t) \quad f_1'(t)$

$f_1(t)$

$f_1'(t)$

| | | |
|--|--|------------------------------|
| | | $f_1(t)$ $f_1(t) f_1'(t)$ |
| | | |
| | | |
| | | |

$f_1(t) f_2(t)$

$f_2(t)$

| | | |
|--|----------|-----------------------------|
| | | |
| | $f_1(t)$ | $f_2(t)$ $f_1(t) f_2(t)$ |

$f(t)$

$f(t)$

$(t_1, t_1 + T)$

$$f(t) = a_0 + \sum_{n=1}^{\infty} (a_n \cos n\Omega t + b_n \sin n\Omega t)$$

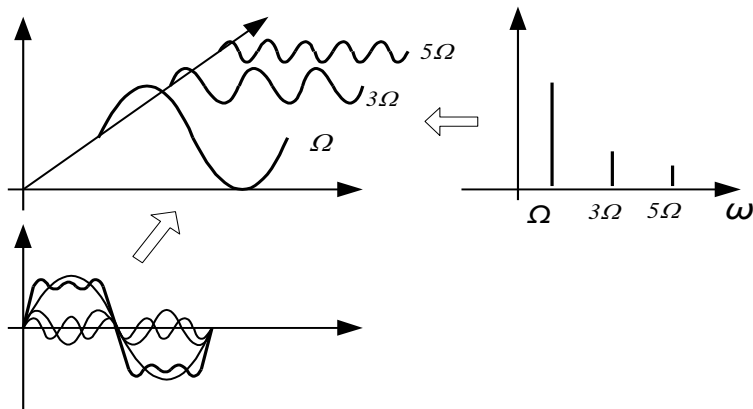

| | |
|--|--|
| | |
| | |
| | |
| | |
| | |

| | |
|--|--|
| | |
| | |
| | |
| | |
| | |
| | |
| | |

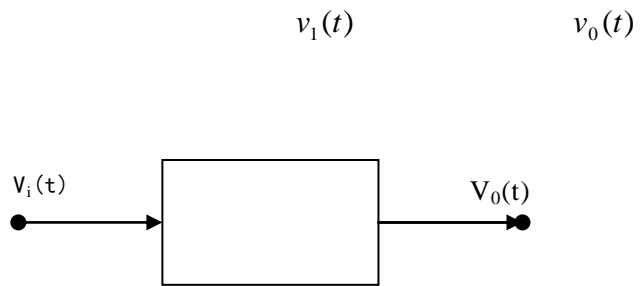

$$\frac{d\varphi(\omega)}{d\omega} (s)$$

ω_H

ω_H

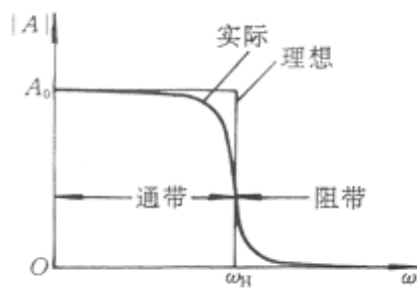
ω_H ω_L ω_L ω_L ω_H ω_0 ω_L ω_H ω_H ω_L ω_H ω_L ω_H ω_L ω_L ω_H ω_L ω_0 

(a)

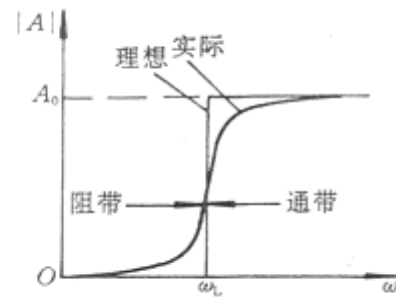

(b)

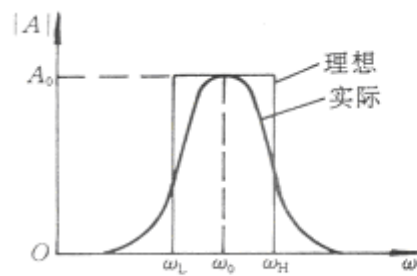

(c)

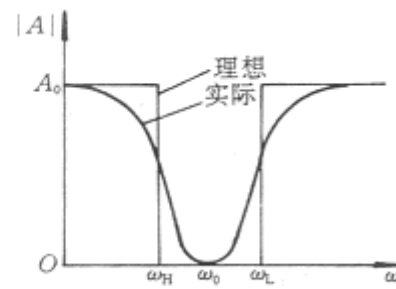

(d)

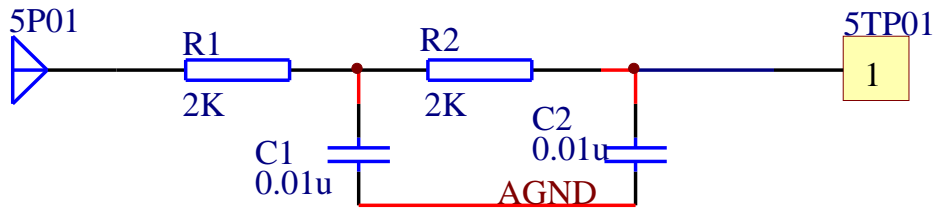

3-3 a

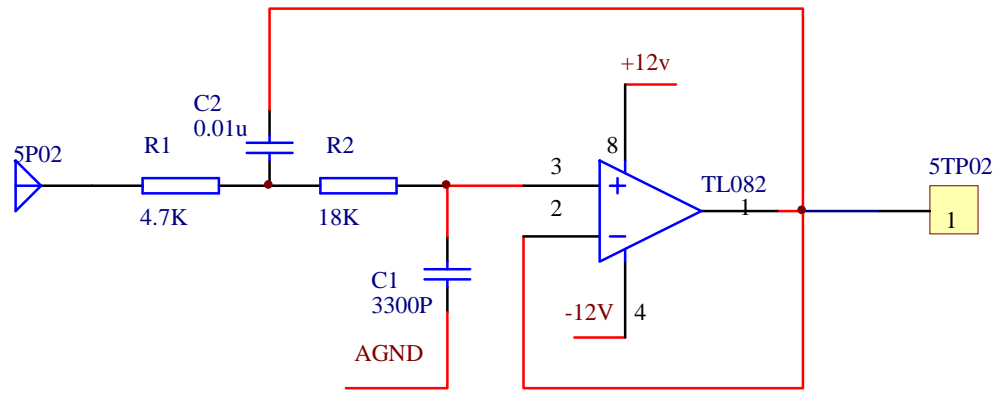

3-3 b

| | | | | | | | | | | |
|--|--|--|--|--|--|--|--|--|--|--|
| | | | | | | | | | | |
| | | | | | | | | | | |
| | | | | | | | | | | |

| | | | | | | | | | | |
|--|--|--|--|--|--|--|--|--|--|--|
| | | | | | | | | | | |
| | | | | | | | | | | |
| | | | | | | | | | | |

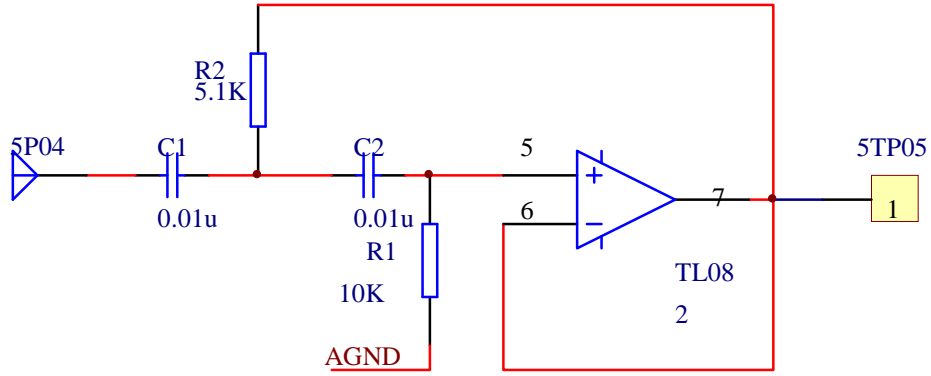
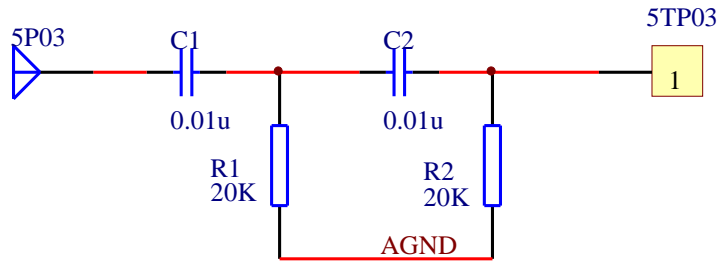

| | | | | | | | | | | |
|--|--|--|--|--|--|--|--|--|--|--|
| | | | | | | | | | | |
| | | | | | | | | | | |
| | | | | | | | | | | |

| | | | | | | | | | | |
|--|--|--|--|--|--|--|--|--|--|--|
| | | | | | | | | | | |
| | | | | | | | | | | |
| | | | | | | | | | | |

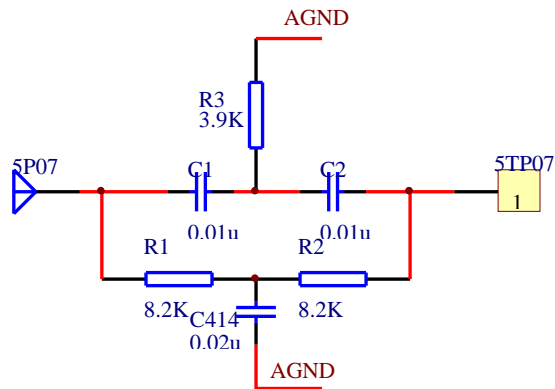

3-5 a

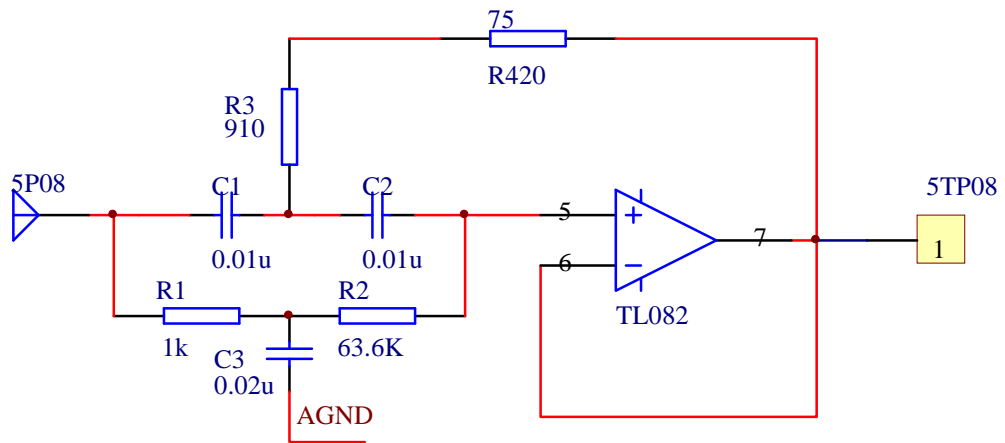

3-6 b

| | | | | | | | | | | | | |
|--|--|--|--|--|--|--|--|--|--|--|--|--|
| | | | | | | | | | | | | |
| | | | | | | | | | | | | |
| | | | | | | | | | | | | |

| | | | | | | | | | | | | |
|--|--|--|--|--|--|--|--|--|--|--|--|--|
| | | | | | | | | | | | | |
| | | | | | | | | | | | | |
| | | | | | | | | | | | | |

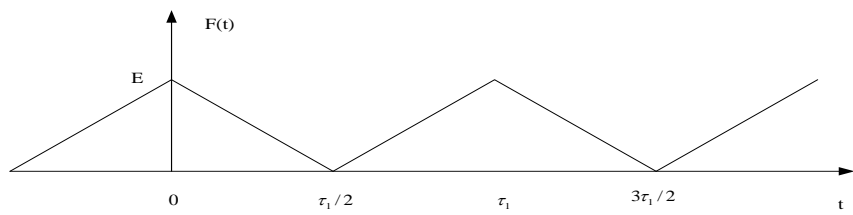

(a)

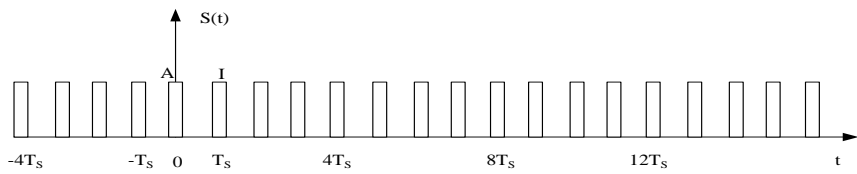

(b)

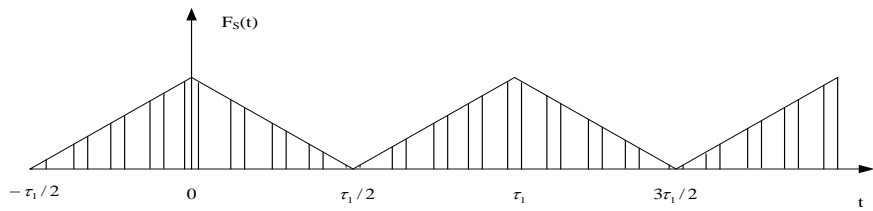

(c)

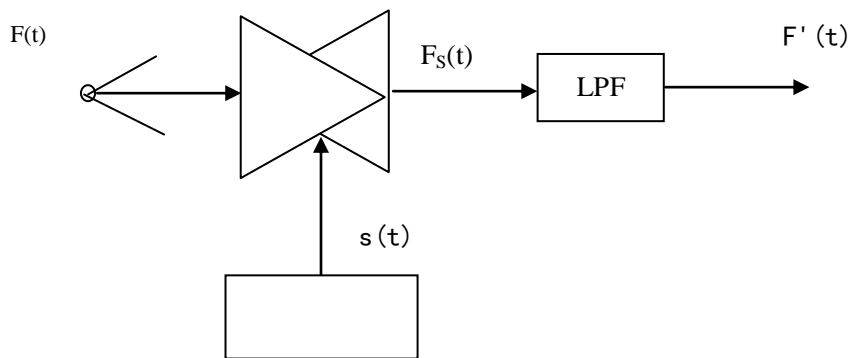

$$F_S(j\omega) = \frac{A\tau}{T_s} \sum_{m=-\infty}^{\infty} Sa\left(\frac{m\omega_s\tau}{2}\right) \bullet 2\pi\delta(\omega - m\omega_s)$$

$$\frac{\omega_s}{2\pi} \quad \frac{A\tau}{T_s} \quad \frac{m\omega_s\tau}{2}$$

$$E\pi \sum_{K=-\infty}^{\infty} sa^2\left(\frac{k\pi}{2}\right) \delta\left(\omega - k\frac{2\pi}{\tau_1}\right)$$

$$\frac{EA\tau\pi}{TS} \sum_{k=-\infty}^{\infty} Sa\left(\frac{m\omega_s\tau}{2}\right) \bullet Sa^2\left(\frac{k\pi}{2}\right) \bullet \delta\left(\omega - k\omega_1 - m\omega_s\right)$$

$$\omega_1 = \frac{2\pi}{\tau_1} \quad f_1 = \frac{1}{\tau_1}$$

$$\omega_1 f_s = 8f_1$$

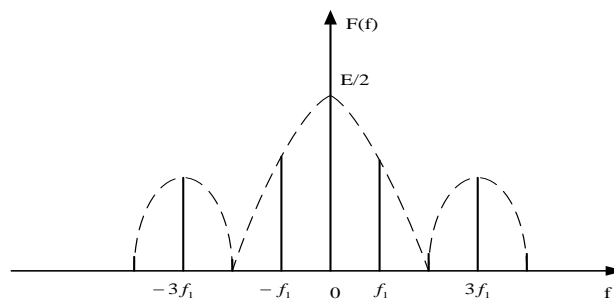

(a)

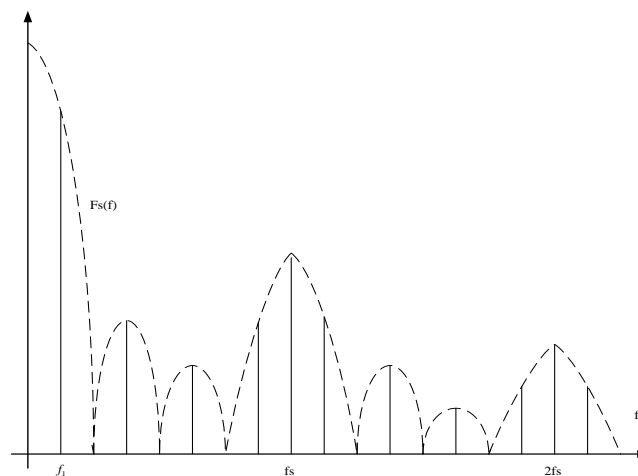

(b)

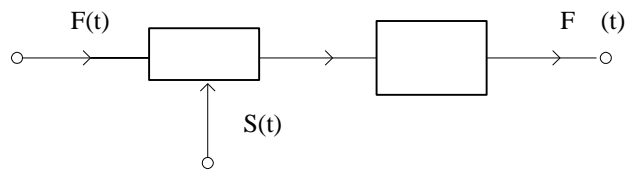
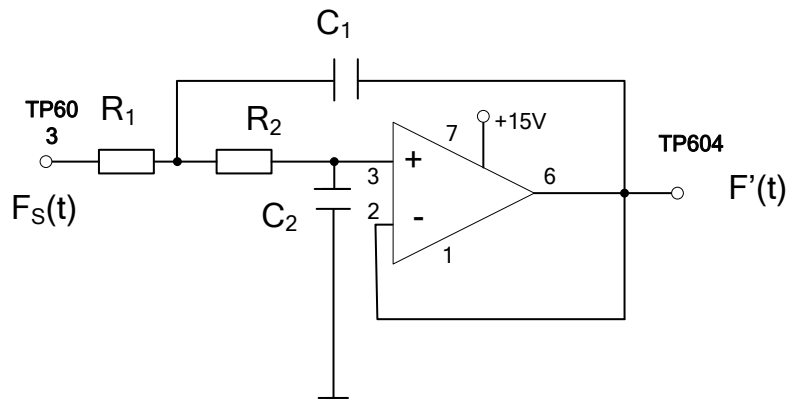

|

| | |
|--|--|
| | |
| | |

| | |
|--|--|
| | |
| | |

| | |
|--|--|
| | |
| | |