

2018 8

实验一 常用电子仪器的使用

1

1

2

3

4

2

1 DS-5000

2 TH SG10

3 FLUKE-15B

4

3

4

1

FLUKE-15B

1.1.1

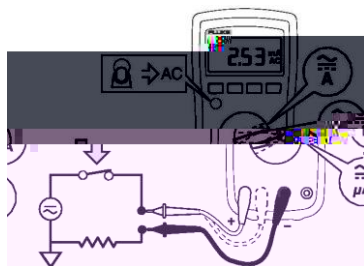

1.1.1

+5V -5V +12V -12V 0~35V

2 TH-SG10



1.1.2 TH-SG10

TH-SG10

1.1.2

FSK PSK

TTL

10mHz 10MHz

Z

⁻⁵Hz

2mV 20V_{P-P}

1mV 10V_{P-P}

V_{P-P}

V_{P-P}

V_{P-P}

-

V_{P-P},10KHz

1

2

3

P-P

4

f=1KHz 50mV_{P-P}

3 DS-5000



1.1.3 DS-5000

DS-5000

1.1.3 ,

DS-5000

1

GROUND

2

/

1

2

/

s/

3-5

50%

DS-5000

1

2

CH1 CH2;

3

DS-5000

-

$f=1\text{KHz}$ $50\text{mV}_{\text{p-p}}$

CH1

4

, , ,

$f=1\text{KHz}$ $50\text{mV}_{\text{p-p}}$

5

1

2

3

4

5

实验二 单级放大电路

1

1

2

3

A_u

R_i

R_o

4

2

1

2

3

4

5

3DG6

3

1
2
4

1.1.4

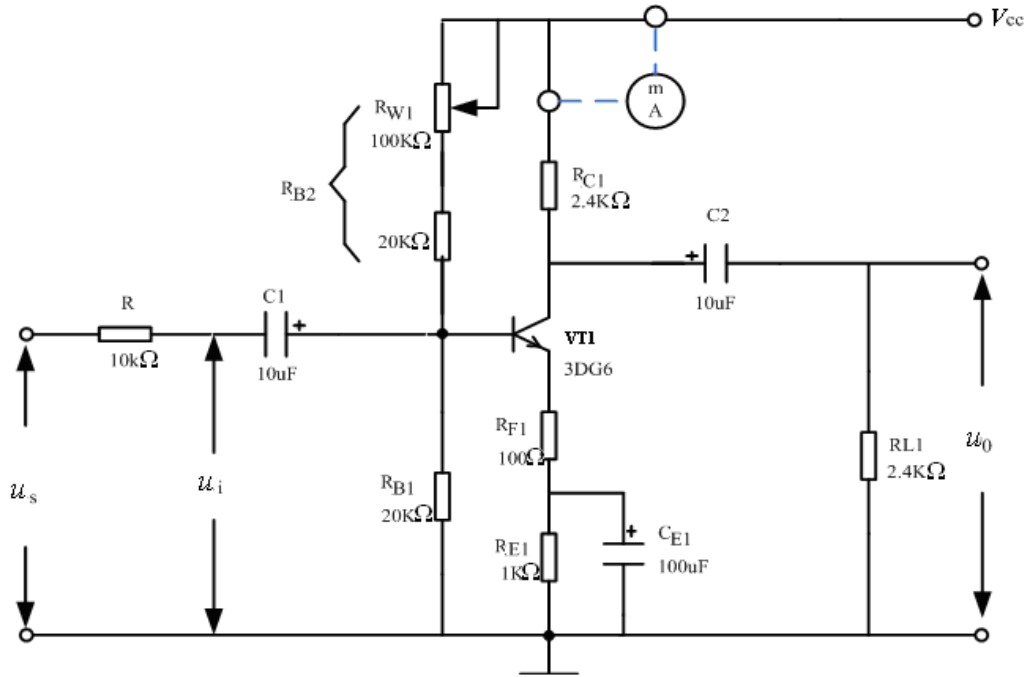

1.1.4

1
1)
2)

$+12V$ u_i u_s R_{W1} $V_E=2.2V$ U_{BEQ}
 U_{CEQ} R_{B2} 1.1.1

1.1.1

U_{BEQ}/V	U_{CEQ}/V	$R_{B2}/$

3) R_{W1} $V_E=2.2V$ I_C VT_1 V_B R_{B2}
 R_{B1} 1.1.2 VT_1 I_B β

$$I_B = \frac{V_{CC} - V_B}{R_{B2}} - \frac{V_B}{R_{B1}} \quad \beta = \frac{I_C}{I_B}$$

1.1.2 I_B β

1.1.2

I_C /mA	V_B /V	R_{B2} /k	R_{B1} /k	I_B /mA	β

2

1 $f=1\text{KHz}$ - 50mV

u_i u_i u_o u_i u_o 1.1.3

2) u_i $f=1\text{KHz}$ u_i u_o u_o

1.1.3

1.1.3

u_i /mV	u_o /V	A_u	A_u
50mV _{P-P}			

u_i u_o

1.1.3 - U_{P-P} U_{RMS}

3) u_i - 50mV $f=1\text{kHz}$ R_{L1} R_{L1}

1.1.4

1.1.4

R_{C1}	R_{L1}	u_i (V)/ V_{P-P}	u_o (V)/ V_{P-P}	A_u	A_u
2.4k	2.4K				
2.4k	10K				

4) u_i - 50mV $f=1\text{kHz}$ R_{W1} u_o

U_B U_C U_E 1.1.5

1.1.5

R_{W1}	U_B/V	U_C/V	U_E/V	u_O

U_i

5)

10k

1.1.5

u_s u_i

1.1.6

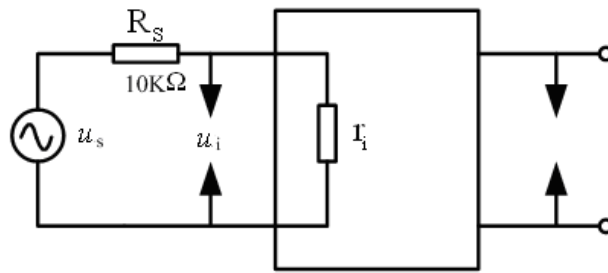

1.1.5

6)

1.1.6 , R_L

R_L

u_o

1.1.6

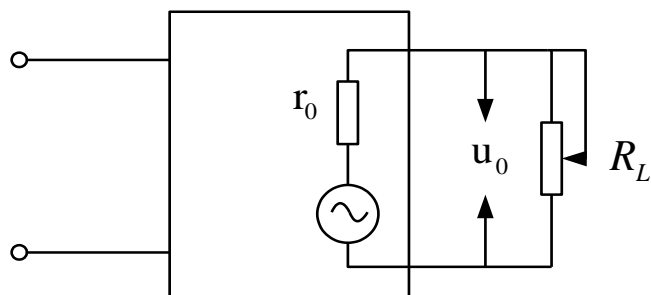

1.1.6

1.1.6

U_s/mV	U_i/mV	$R_i/$	$R_i/$	U_o/V R_L	U_o/V $R_L=2.4K$	$R_o/$	$R_o/$

5

1

2

3

实验三 射极跟随器

1

1

2

2

1

2

3

4

5

6

3DG6

3

1

2

4

1.1.7

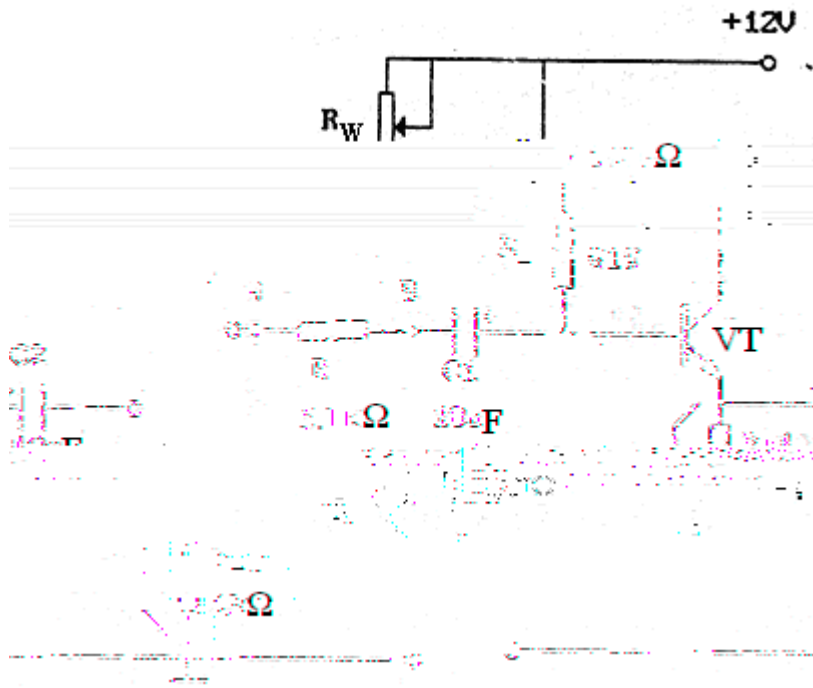

1.1.7

1

1.1.6 +12V B f 1KHz $U_i(U_i$ 100mV)

R_W

U_i 0

1.1.7

1.1.7

U_E/V	U_B/V	U_C/V	$I_E = \frac{U_E}{R_E} / mA$

R_W (I_E)

2

A_u

R_L

B

f 1KHz

U_i

U_O

U_i U_L

1.1.8

1.1.8

U_i/V	U_L/V	$A_u = \frac{U_L}{U_i}$

3

R_O

R_L

B

f 1KHz

U_i (

100mV

)

$$A_{d1} = \frac{U_{c1}}{U_i} \quad A_{d2} = \frac{U_{c2}}{U_i} \quad A_d = \frac{|U_{c1}| + |U_{c2}|}{U_i} \quad A_{d1}$$

$$A_{d2} \quad A_d$$

3)

A B ()

A B

$$U_i = 1V \quad f = 1KHz$$

$$U_{c1} \quad U_{c2} \quad U_i \quad U_{c1} \quad U_{c2} \quad U_{RE}$$

U_i

$$A_{c1} = \frac{U_{c1}}{U_i} \quad A_{c2} = \frac{U_{c2}}{U_i} \quad A_c = \frac{|U_{c1}| - |U_{c2}|}{U_i} \quad A_{C1}$$

$$A_{C2} \quad A_C$$

2

1.1.8

K

1

5

1

1)

2)

CMRR

3)

CMRR

CMRR

2

$$U_i \quad U_{C1} \quad U_{C2}$$

实验五 负反馈放大电路

1

1

2

3

2

1

2

3

4

5 3DG6×2

3

1

;

2

($\beta_1 \beta_2 = 100$);

3

$A_{uf} ? \quad ? \quad ?$

4

;

5

EWB Multisim

4

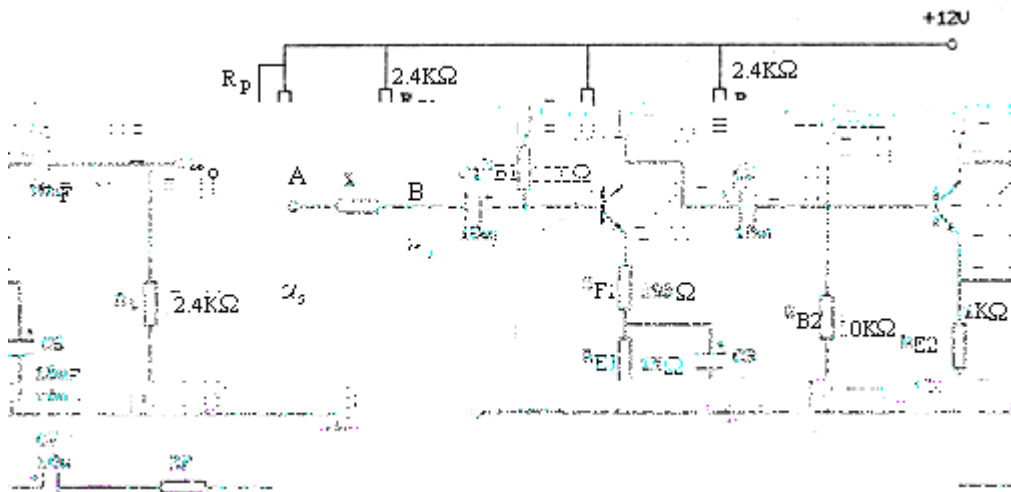

1.1.9

1.1.9

1

1

1.1.9

3DG6 R_L

U_i

0

1.1.12

1.1.12

	U_B/V	U_E/V	U_C/V	I_C/mA

2

A_u

B

1KHz

50mV

3) u_o u_o u_o

R_o $50mV$ R_L U_o

$R_o = \left(\frac{U_o'}{U_o} - 1\right) R_L$ R_o

4) R_i R A $1KHz$

$U_{ipp} = 50mV$ A U_{Spp} $R_i = \frac{U_i}{U_s - U_i} R_s$

R_i

5) R_L B $50mV$ $1KHz$ $U_L(U_L$

) ($U_{ipp} = 50mV$) f_H f_L

$f_{BW} = f_H - f_L$

2 1

1

2 1 $R_F = 2$ 1

A_{uf} R_{of} R_{if} f_{BW}

3 2

1

2 1 $R_F = 2$ 1

A_{uf} R_{of} R_{if} f_{BW}

4

1) f $1KHz$

2) 1)

5.

(1)

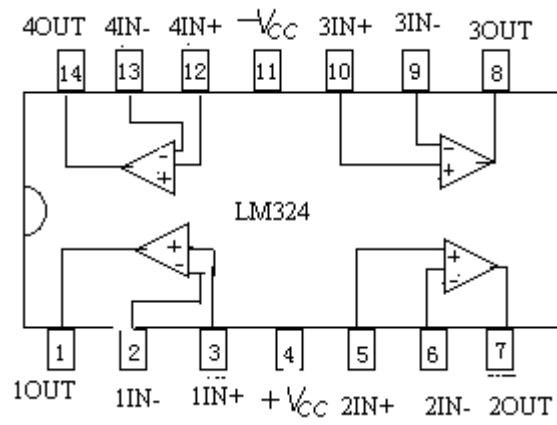

1.1.11 LM324

1.1.13

U_o	/mV				

2 1.1.15

1.1.15

$\Delta U_o/V$	R_L U_i 0 800mV		
$\Delta U_{AB}/V$			
$\Delta U_{R2}/V$			
$\Delta U_{R1}/V$			
$\Delta U_{OL}/V$	$U_i=800mV$ R_L		

3

1.1.13

1.1.16 1.1.17

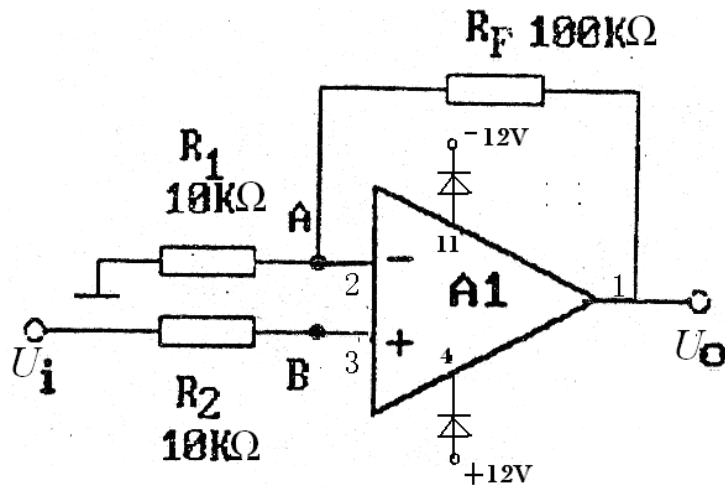

1.1.13

1.1.16

	U_i/mV	100	300	1000	3000
U_o	/mV				
	/mV				

1.1.17

$\Delta U_O/V$	R_L U_i 0 800mV		
$\Delta U_{AB}/V$			
$\Delta U_{R2}/V$			
$\Delta U_{R1}/V$			
$\Delta U_{OL}/V$	$U_i=800mV$ R_L		

4

1.1.14

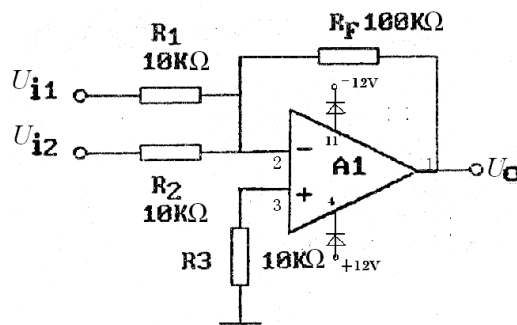

1.1.14

1.1.18

1.1.18

U_{i1}/V	0.3	0.1
U_{i2}/V	0.2	0.2
U_O/V		

5

1.1.15

1.1.19

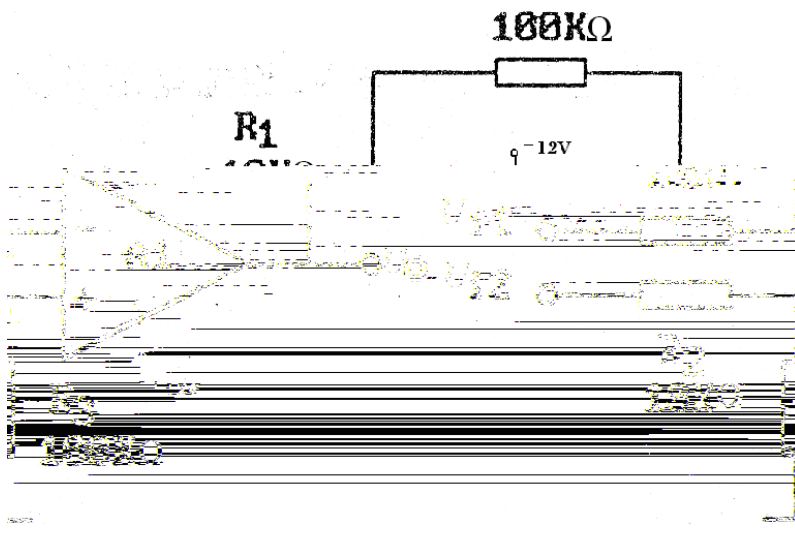

1.1.15

1.1.19

U_{i1}/V	0.3	0.1
U_{i2}/V	0.2	0.2
U_o/V		

5.

(1)

(2)

实验七 信号发生与功放综合电路

1

1 OTL

2 OTL

3 RC

4

(5)

2

(1)

160Hz-20KHz

(2)

(3)

(1) 0.1W 5W

2 R_L

3

4 η

3

1 OTL

2

3

4 EWB Multisim

4

1 2

3 4

5 6 LM324

7 8

9 3DG6 (9011) 3DG12 (9013) 3CG12 (9012) IN4007

5.

1.1.16

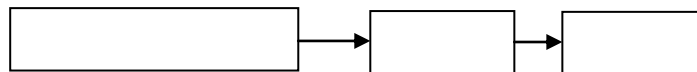

(1)

RC



图 1.1.17 RC

RC

1.1.17

RC

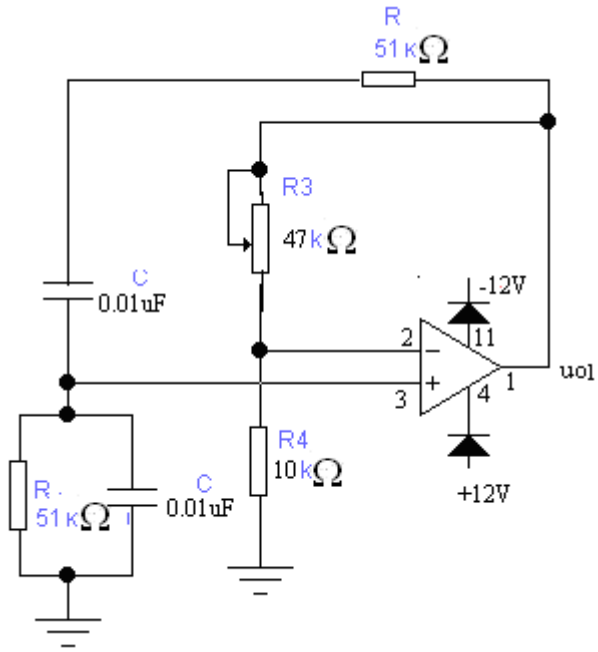
Z_1

RC

Z_2

$$Z_1 = R + (1/j\omega C) \quad Z_2 = R // (1/j\omega C) = \frac{R}{1 + j\omega RC}$$

$$\dot{F} = \frac{Z_2}{Z_1 + Z_2} = \frac{1}{3 + j(\omega RC - \frac{1}{\omega RC})}$$

$$f_0 = \frac{1}{2\pi RC} \quad \dot{F} \quad \left| \dot{F} \right|_{\max} = \frac{1}{3}$$

$$|\dot{A}\dot{F}| > 1 \quad A_f > 3 \quad R_3 R_4$$

$$A_f = 1 + \frac{R_3}{R_4} > 3$$

(2)OTL

$$\eta = \frac{P_{om}}{P_E} 100\%$$

$$\eta_{\max} = 78.5\%$$

$$I_{dc}$$

$$P_E = V_{cc} I_{dc}$$

6

1

1

R_{W2}

;

R_{W2}

2) P_{0m} η

a. P_{om}

f 1KHz

u_i

u_0

u_i

u_O

R_L

U_{om}

1.1.21

1.1.

a b

4

$(u_i = 0)$

U_N U_N 15mV

(2) ()

1) 1.1.17 LM324 1.1.19 $\pm 12V$

R_3 u_O

R_3 R_3 1.1.23

1.3.6

1.1.23

R_3	U_O/V	u_O	

2) R_3 u_O U_O

U_+ U_-

f_O R

1.1.20

1.1.24

1.1.24

R/k	$C/\mu F$	f_O/Hz	f_O/Hz

3) 1.1.21 u_{O2}

R_3 1.1.

1.1.25

$R_3/$	u_{o2}	/Hz	u_{o2}	/V

4) u_{o2} 100mV R_3

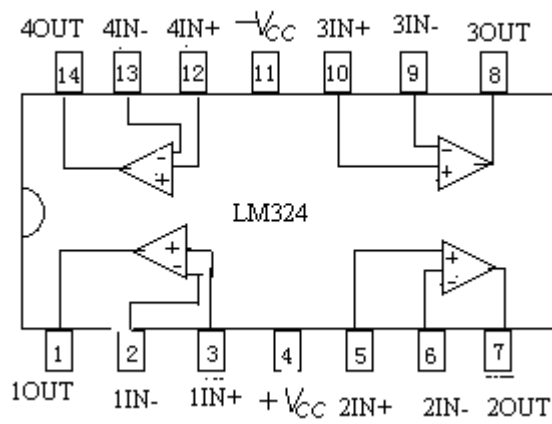

1.1.19 LM324

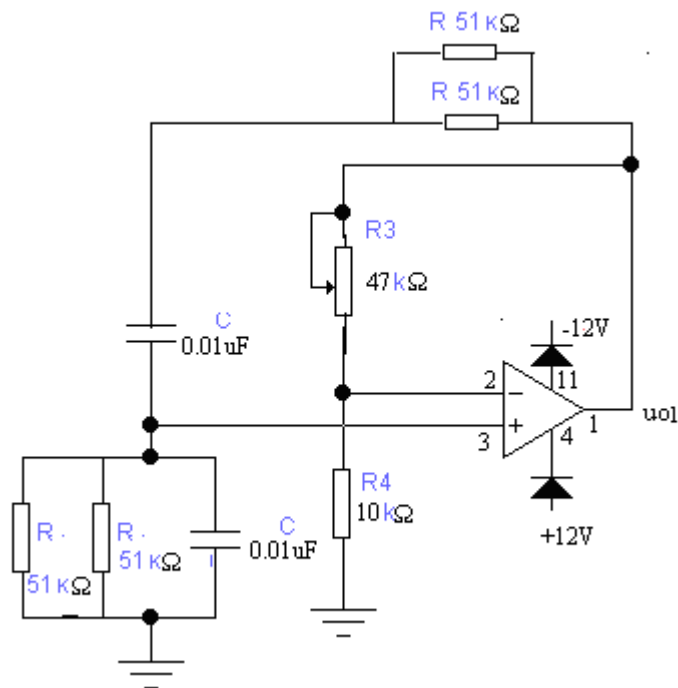

1.1.20

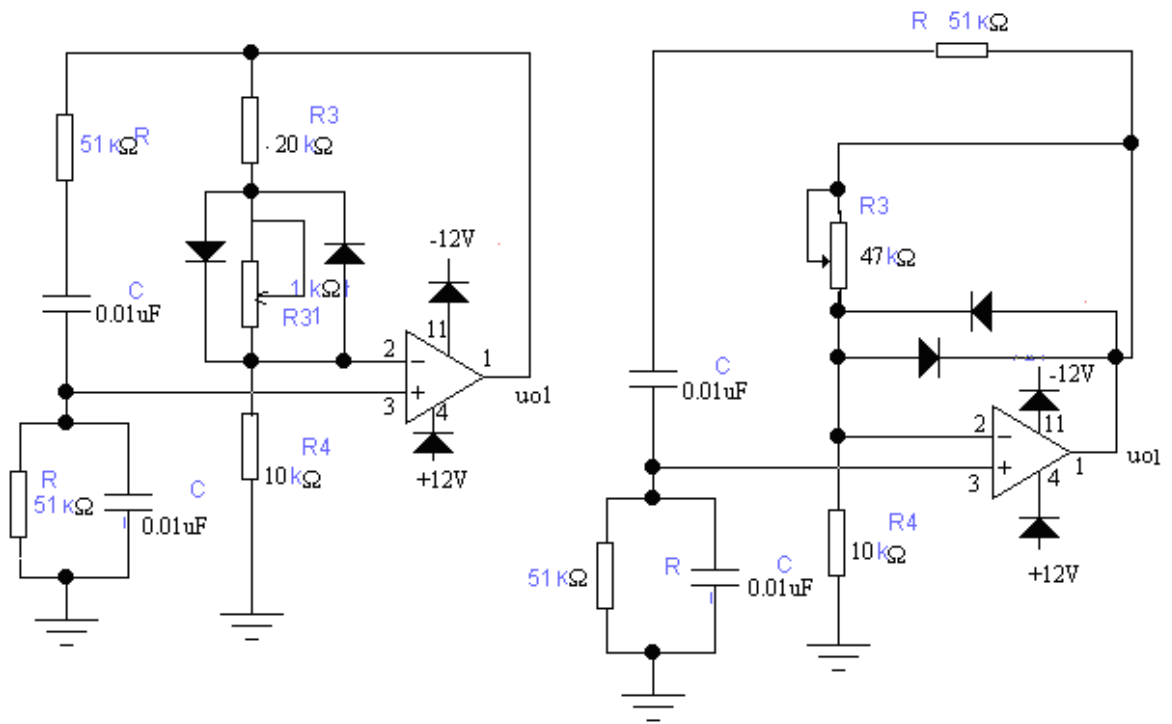

1.1.21

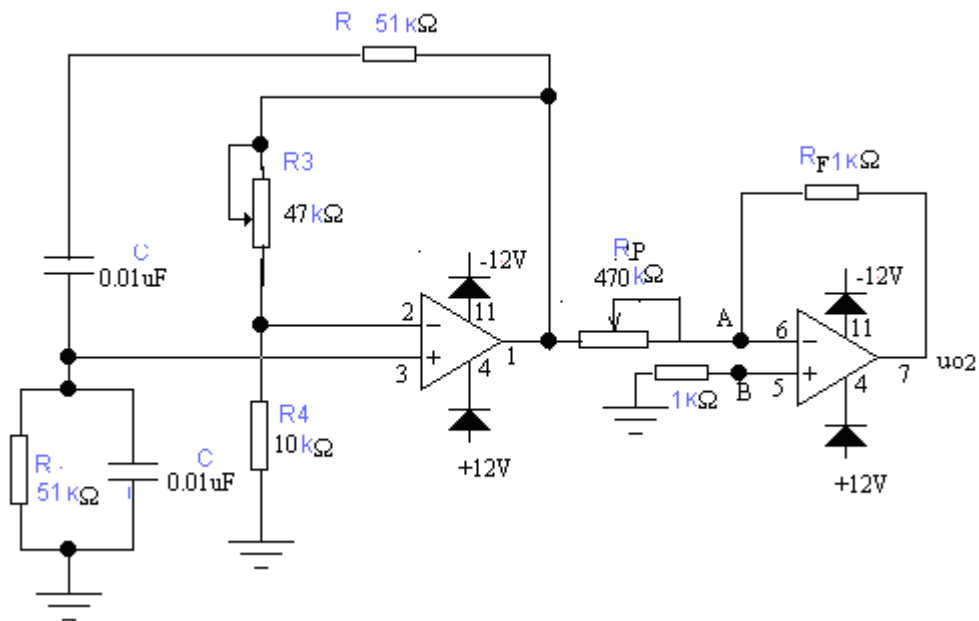

1.1.22

(3) u_o

1.1.23 1.1.24 1.1.25



图 1.1.23



图 1.1.24

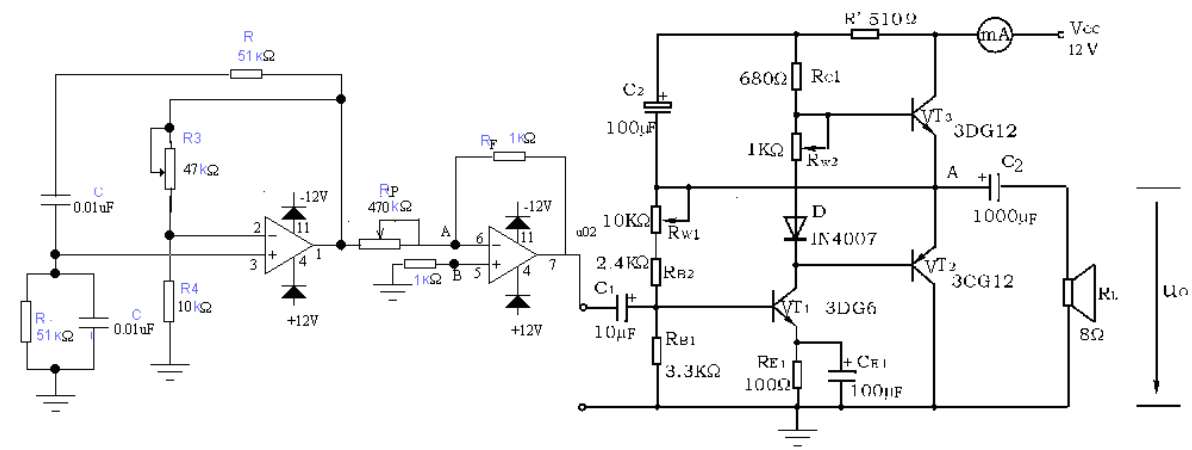

图 1.1.25

1

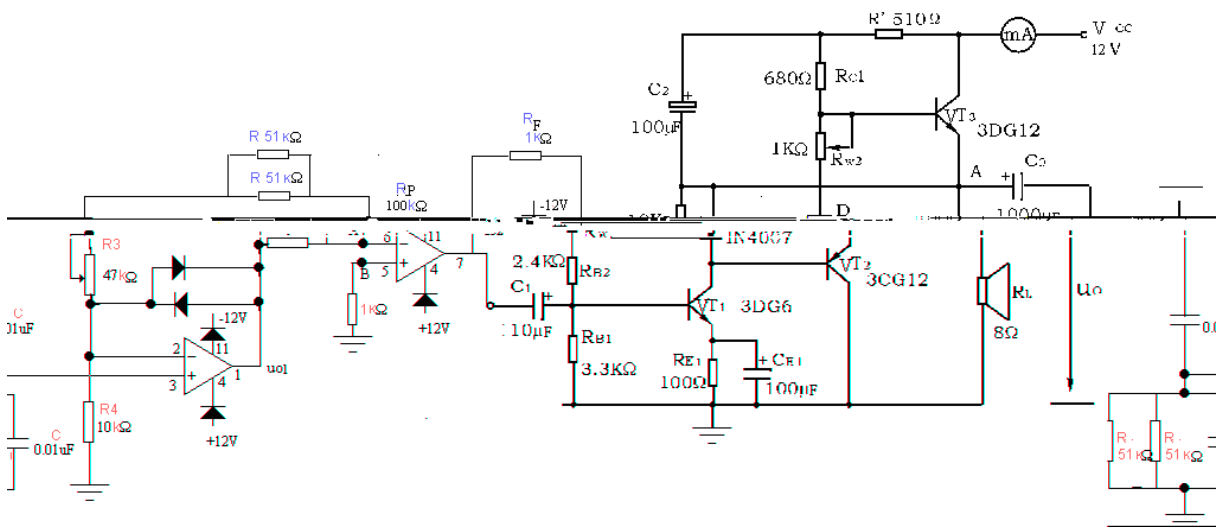
2

3

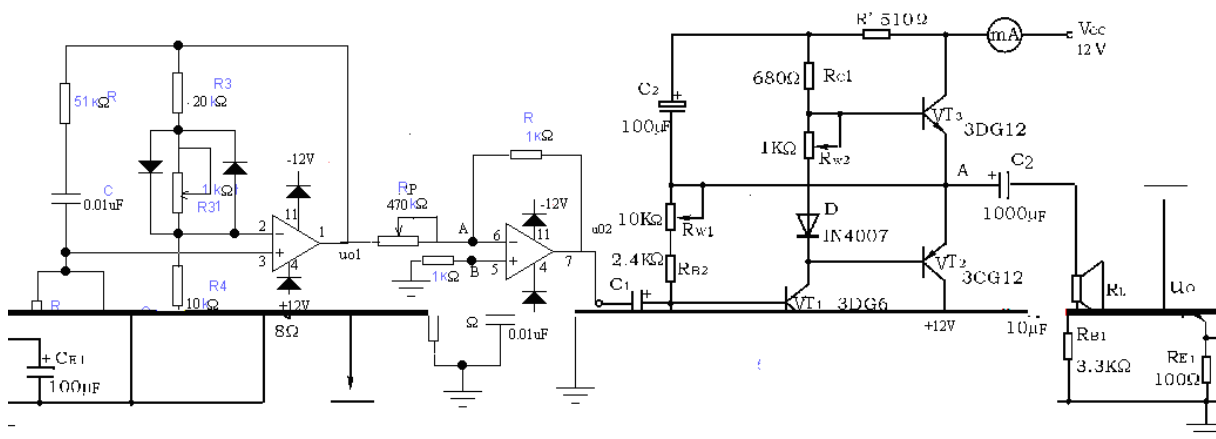
4 EWB Multisim

5

()

6

7

实验八 直流稳压电源

1

1

2

3

2

1

2

3

4

U_o U_o 9V VT₁ VT₂

U_{CE1S}

5

EWB Multisim

3

1

2

3

4

5

6

7

8

3DG6 3DG12 (9013)

IN4007

IN4735

4

(1) U_o

$$U_o = \frac{R_1 + R_w + R_2}{R_2 + R_w} U_z U_{BE2}$$

R_w U_o

(2) R_o

R_o U_i

$$R_o = \frac{\Delta U_o}{\Delta I_o} \Big|_{U_i = \text{const}}$$

(3) S

$$S = \frac{\Delta U_o / U_o}{\Delta U_i / U_i} \Big|_{R_L = \text{const}}$$

(3)

5

(1)

1.1.28 1.1.29

U_2 U_L

U_2 U_L

1.1.26

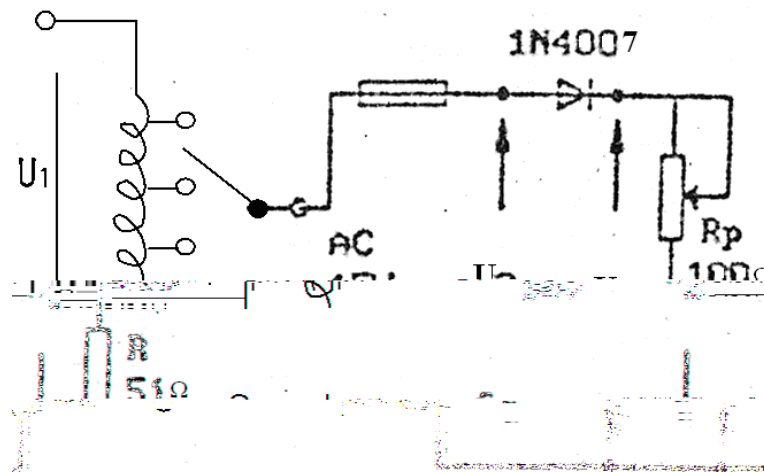

1.1.28

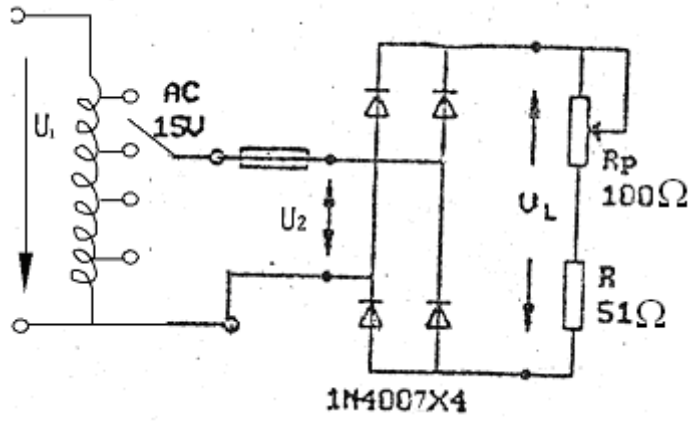

1.1.29

1.1.26

	1.3.19	1.3.20
U_2		
U_L		
U_2		
U_L		

(2)

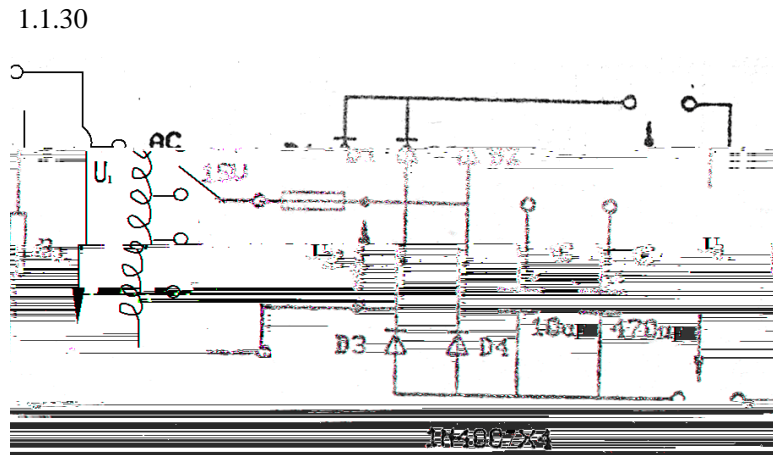

1.1.30

1 R_L U_L 1.3.9

2 R_L R_L 1.1.27

1.1.27

		U_L	U_L
--	--	-------	-------

R_L	10uF		
	470uF		
R_L	10uF		
	470uF		

(3)

1 9-15V

2 $I_o = 100mA$

3 $S_r < 0.5\%$

1 16V

U_1 U_O R_W U_O
 R_W
 U_Z U_1 U_O
 U_{BE} U_{CE}

2

R_W U_{omin} U_{omax}

3

S

I_O 100mA 1.3.11 U_2

U_1 U_O 1.1.29

1.1.29 I_O 100mA $U_2=16V$

U_2/V U_1/V U_O/V

4

R_O

$U_2=16V$ I_O 50mA 100mA U_O 1.1.30

1.1.30 $U_2=16V$

5

U_2 16V U_O 9V I_O 100mA \bar{U}_O

6)

a. R_W R_L $U_O=9V$ $I_O=100mA$

VT_3

b. R_L I_O 120mA U_O VT_3

R_4

c.

6

1

2 U_O 9V U_{Imin}

U_{2min}

3 U_O R_W

4

5 S R_O

7

1

2

3 EWB Multisim

5

6