

电力系统电气部分设计

实验指导书

山东理工大学

电气与电子工程学院

2015. 3

实验一 具有事故灯光控制的断路器控制回路实验

4.1.1 实验目的

- (1)
- (2)

4.1.2 实验原理及实验说明

4.1.2.1 具有事故灯光控制的断路器控制回路的实验原理

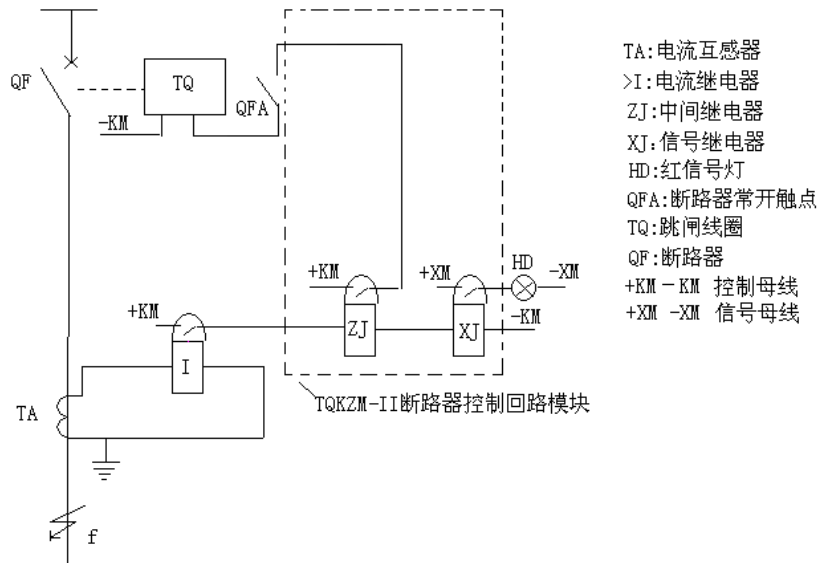
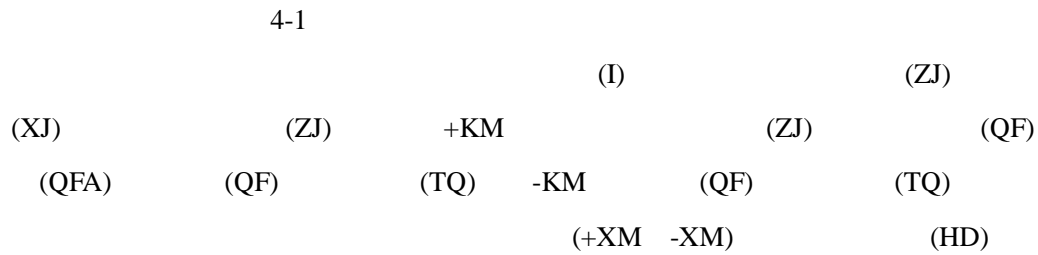

- TA: 电流互感器
- >I: 电流继电器
- ZJ: 中间继电器
- XJ: 信号继电器
- HD: 红信号灯
- QFA: 断路器常开触点
- TQ: 跳闸线圈
- QF: 断路器
- +KM -KM 控制母线
- +XM -XM 信号母线

4.1.2.2 TQKZM-II 型断路器控制回路模块简介及工作原理

- (1) TQKZM-II
- TQKZM-II

4-2

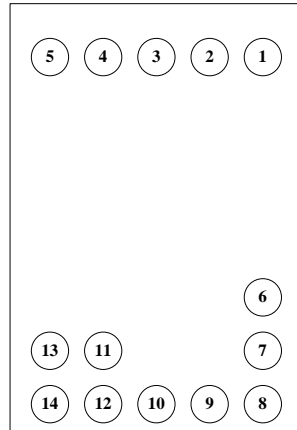

4-2 TQKZM-II

1		+KM		
2		TZ	TZ	10 TQ
3		HZ	HZ	9 HQ
4			BS	
5			+KM	
6	7			
8			-KM	
9		HQ		HQ
10		TQ		TQ
11	13			3 HZ
			5	
12	14			4 TZ
			5	

(2) TQKZM-II

TQKZM-II

4-3

4-3	FTJ		BSJ		HXJ
TXJ			HBJ		TBJ
					FGJ

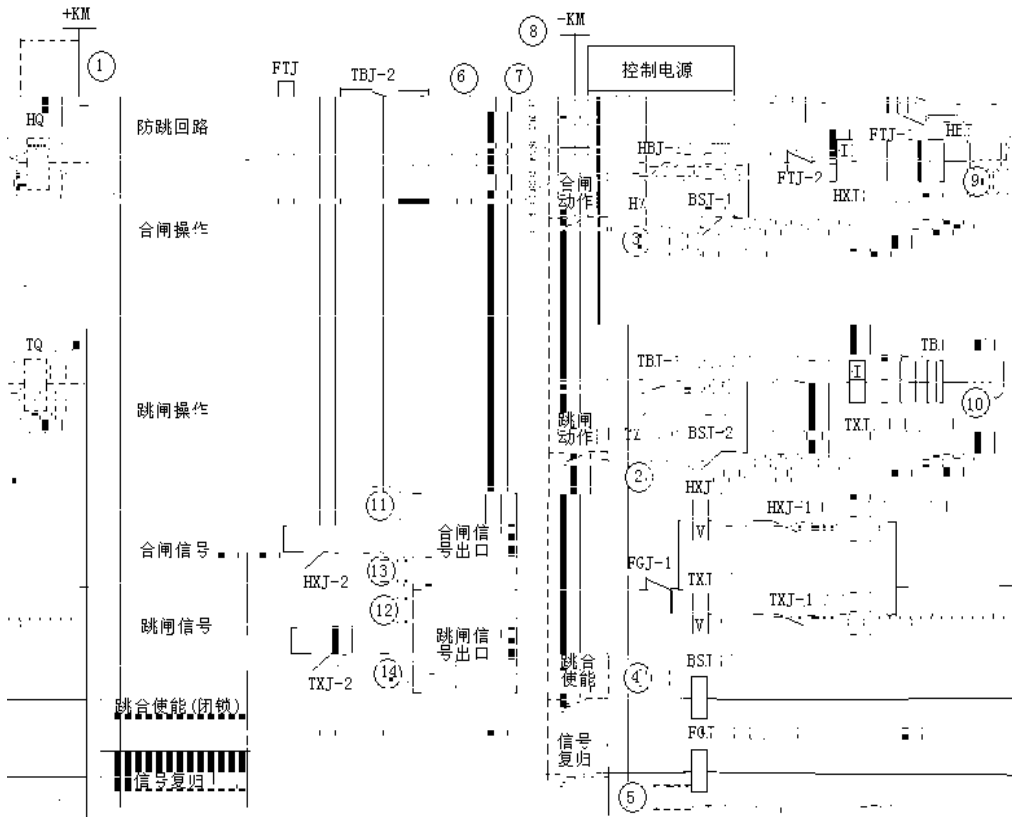

4-3 TQKZM-II

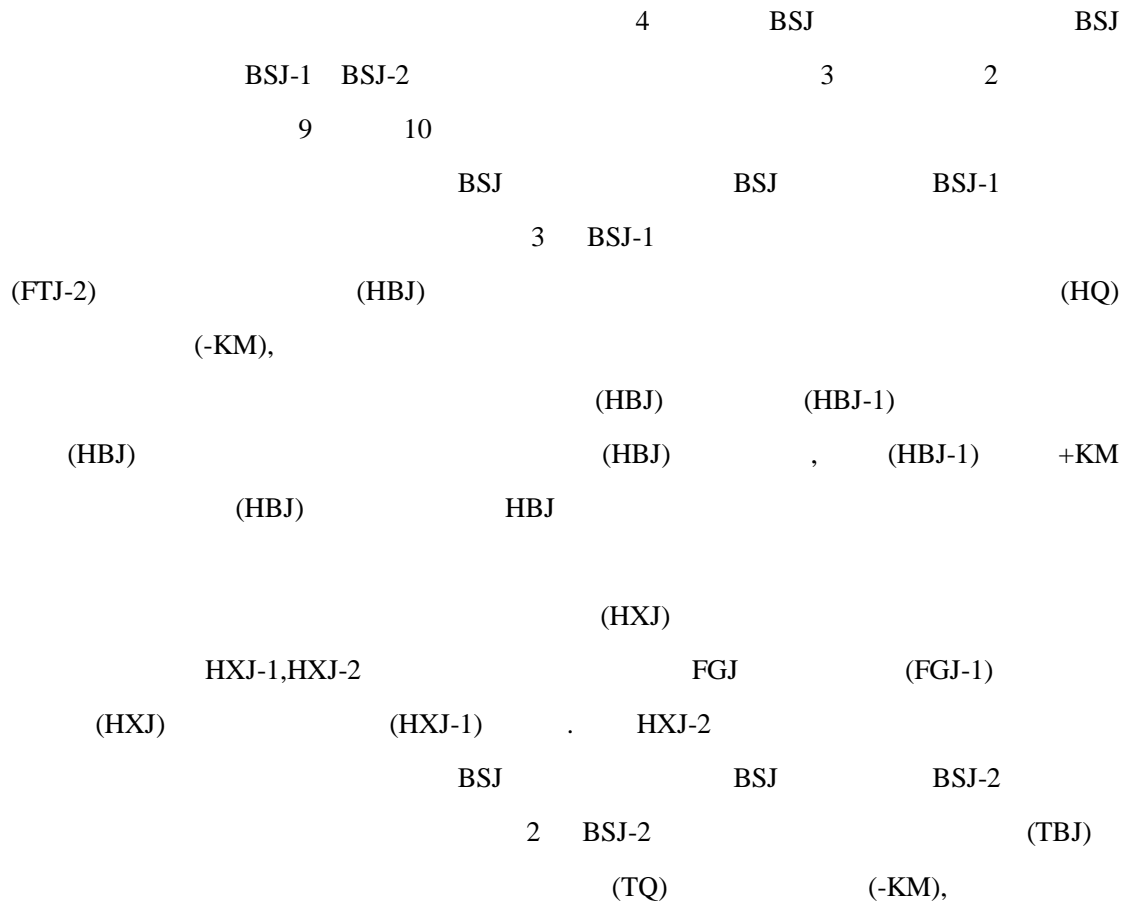

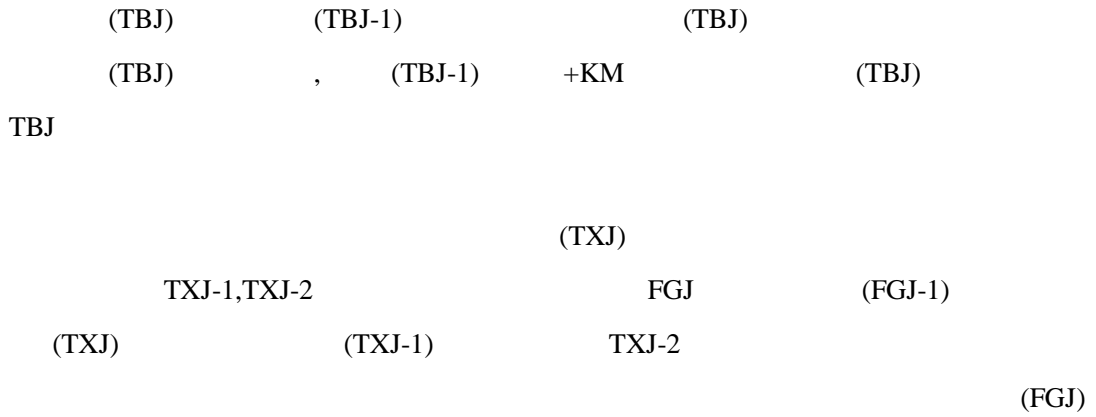

4. 1. 2. 3 断路器控制回路实验说明

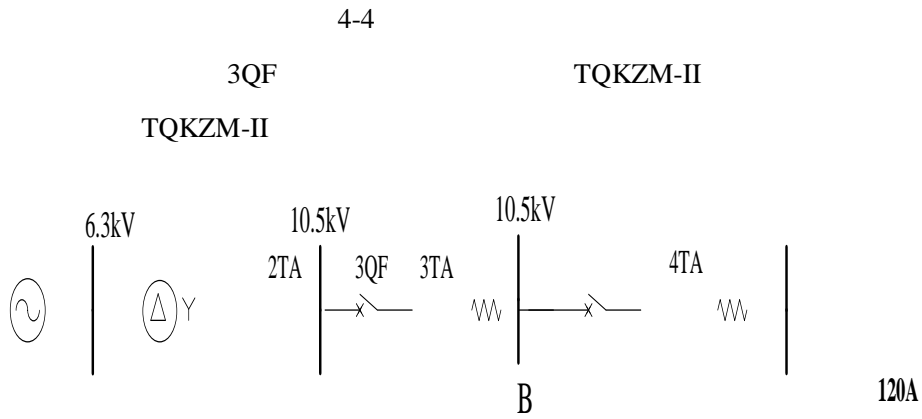

4-4

4. 1. 3 实验内容

4. 1. 3. 1 实验接线

4-5

1)



2)

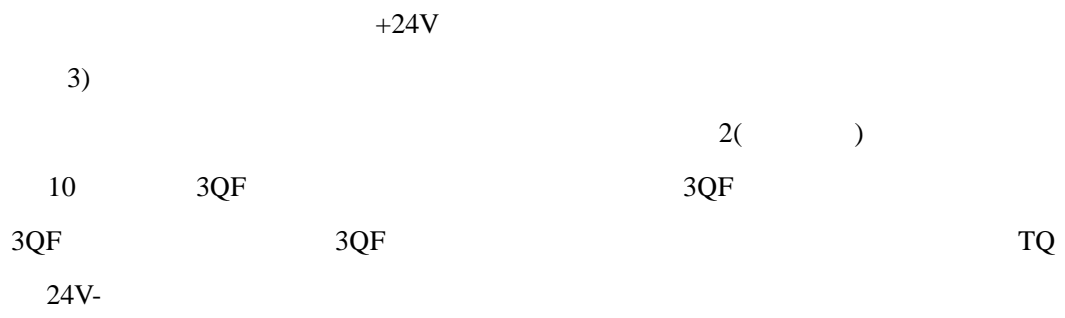

	+KM	KM	24V+	24V-
6)				
24V+				12
	A	K	24V-	14
7)				
			5	
24V+				

实验二 具有防跳功能的断路器控制回路实验

4.2.1 实验目的

- (1)
- (2)

4.2.2 实验原理及实验说明

4.2.2.1 实验原理

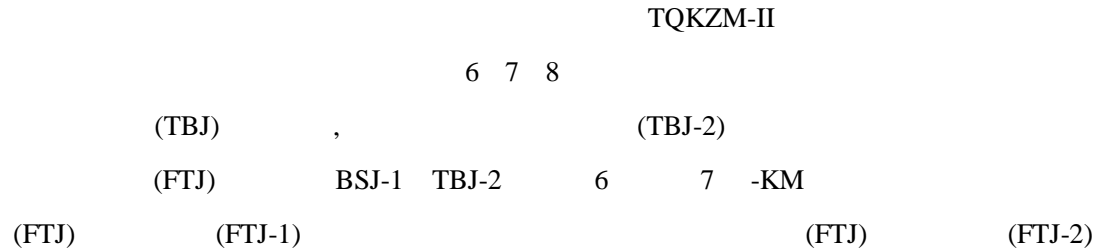

4.2.2.2 实验说明

4.1

4.2.3 实验内容

4.2.3.1 实验接线

4-6

1)

(3QF)

3TA

Ia In

I In

2)

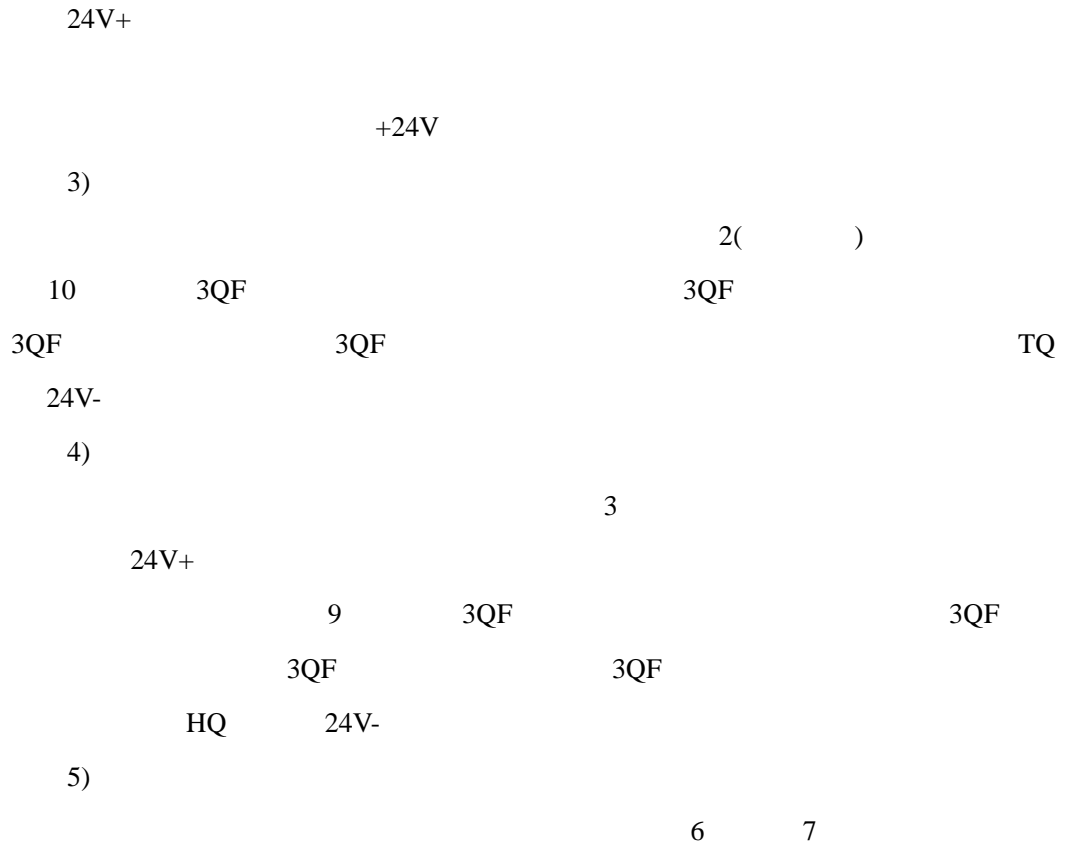

5)

TQ

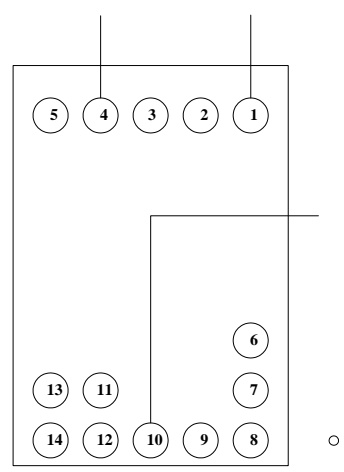

(2)

(4)

a.

b. 3QF 2

(5)

(6) 6 7

(7) 3 4

(8) KM 4

3 4

4.2.4 思考题

(1) ?

(2) ?

(3) ?

实验三 闪光继电器构成的中央信号实验

4.3.1 实验目的

- (1)
- (2)
- (3)

4.3.2 实验原理及实验说明

4.3.2.1 实验原理

LW2

4-7

SA

SM

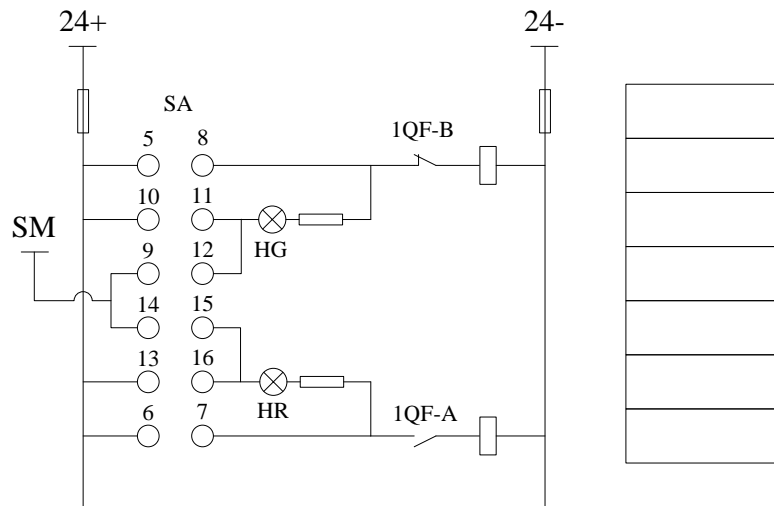

4-7

4.3.2.2 实验说明

SA

4-1

4-2

1	JX-3/1	1
2	SM	1

实验四 冲击继电器构成的中央音响信号实验

4.4.1 实验目的

- (1) JC-2
- (2)

4.4.2 实验说明

4.4.2.1 原理说明

JC-2

JC-2

4.4.2.2 实验设备

4-3

4-3

1	JC-2	1
2		2
3		1
4		1
5	DL-31	1
6	DZY-202	1

4.4.3 实验内容

4.4.3.1 实验接线

4-9

1)

(3QF)

3TA

Ia In

I In

2)

24V+

2()

10

3QF

3QF

3QF

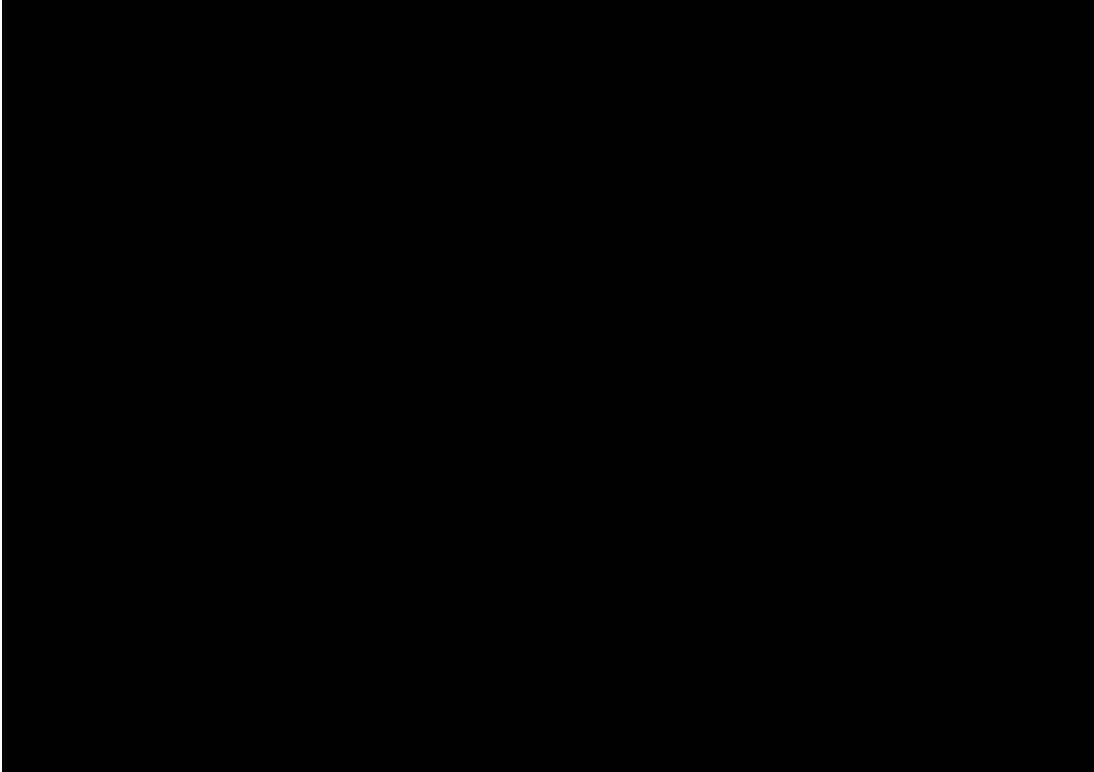

4-9

3)

12 14

4)

(1) 4A

(2)

(4)

(5) 2

(6) 5 24V+ 1

(7) 5 1

(8) 3~6

4.4.4 思考题

1)

2)